

Hakki Pilke

Falcon 35

FIREWOOD PROCESSOR

- Instructions for assembly, operation and maintenance
- EC Declaration of Conformity
- Safety instructions
- Guarantee terms



The operator must read and understand these instructions before operating the machine!

TP SILVA OY

Valimotie 1, FI-85800 Haapajärvi
tel.+358 (0)8 7727300, info@hakkipilke.fi
www.hakkipilke.fi

TP SILVA OY	1
Valimotie 1, FI-85800 Haapajärvi	1
tel.+358 (0)8 7727300, info@hakkipilke.fi	1
www.hakkipilke.fi.....	1
1. General information	4
1.1. Introduction	4
1.2. Purpose of use.....	4
1.3. Machine models and basic information.....	4
1.4. Operating conditions.....	5
1.5. Safety instructions.....	5
1.6. Noise and vibration	5
1.7. Warning symbols.....	6
2. Setting up the machine for operation and transport	8
2.1. Receipt inspection.....	8
2.2. Main components of the machine	8
2.3. Arranging the machine for operation and transport	9
2.4. Connecting the machine to a power source	12
2.5. Combustion engine model – Hakki Pilke Power Unit (accessory).....	14
.....	14
2.6. Lifting and moving the machine.....	14
2.7. Additional hydraulics connections (accessories)	15
3. Operating the machine	16
3.1. Controls and functions of the machine.....	16
3.2. Before using the machine	17
3.3. Performing a test run on the machine.....	17
3.4. Feeding and sawing wood.....	18
3.5. Log splitting.....	19
3.6. Using the out-feed conveyor.....	20
3.7. After use.....	21
4. Maintenance and adjustment of the machine	21
4.1. Disconnecting the machine from its power source	22
4.2. Adjusting the log length	22
4.3. Height adjustment of the splitting blade	23
4.4. Replacing the splitting blade.....	23
4.5. Opening the maintenance hatch and adjusting the length of the splitting stroke.....	24
4.6. Out-feed conveyor belt adjustment and cleaning out-feed conveyor	25
4.7. Changing the oil	28
4.8. Changing the oil of the multiplier gearbox	29
4.9. Conveyor maintenance	29
4.10. Lubrication	31

4.11.	Saw chain lubrication	34
4.12.	Solenoid and pressure regulating valves.....	35
4.13.	Washing and cleaning	37
4.14.	Storage	37
4.15.	Maintenance table	37
5.	Failures and remedial measures.....	38
5.1.	Cause-effect table for failures and their removal.....	38
5.2.	Jamming of the cutting blade.....	39
5.3.	Jamming of wood on the splitting blade.....	39
7.	Guarantee terms	40
8.	EC Declaration of Conformity for the machine.....	41

1. General information

1.1. Introduction

The purpose of this manual is to ensure that the machine is used in the manner intended by the manufacturer, taking safety into consideration. Everyone operating the machine or working in close proximity to it must study this manual carefully.

Operators of the machine are expected to have basic skills in tractor handling, such as utilising the cardan shaft drive and the tractor's lifting equipment. Before commencing work, operators must also familiarise themselves with the machine's control and safety equipment, and ensure their proper operation.

Additional information on TP Silva Oy's products is available on our website at www.hakkipilke.fi.

Keep this manual in the immediate vicinity of the machine.

1.2. Purpose of use

The Hakki Pilke Falcon firewood processor is designed for the preparation of firewood from pruned wood or logs. The firewood processor must not be used to process any treated wood, such as is found in construction waste. Sand, nails or other impurities in the wood may damage the machine.

The maximum diameter of the logs to be split is 35 cm. This limit must not be exceeded. When estimating the diameter of the log you are about to split, note that the shape of the log and other factors, such as branches and burrs, make the actual diameter larger, and may prevent the log from being fed to the machine. Do not split logs that exceed 50 cm in length.

1.3. Machine models and basic information

Model	TR	Electrical	Combi
Driving power	Tractor's cardan shaft (TR)	Electric motor	Tractor's cardan shaft electric motor
Weight	890 kg	930 kg	960 kg
TR/Electrical drive	min 20 hp / max 500 rpm	7.5 kW (min 16 A type D fuse)	7.5 kW (min 16 A type D fuse)
Height/width/length in the transport position	Transport position 250/255/135 (cm)		
In-feed/out-feed conveyor	220/400 (cm)		
Saw bar/chain	bar: 16" groove 1.5 mm, chain: 67 loops, pitch 0.325"		
Max log diameter	35 cm		
Max/min log length	Log max 50 cm; min 17 cm		

The machine's serial number, date of manufacture, weight, operating voltage (electrically operated machines) and model are indicated on the grey type plate located on the machine frame below the locking latch of the out-feed conveyor, on the right side of the operator.

1.4. Operating conditions

- The temperature range within which the machine can be operated is -20 to +30°C. In the winter, the operator must ensure that there is no risk of slipping in the working area.
- The working area must be level and clear of unnecessary items. No unauthorised persons are allowed to enter the working area. The machine may only be used in sufficient lighting conditions. These requirements must be met for the entire duration of the work.
- The machine may not be used indoors.

1.5. Safety instructions

- This device is intended to be operated by only one operator. The danger zone is 10 m from the machine.
- Persons under 18 years of age may not operate the machine.
- The operator must ensure that use of the device does not cause danger to others and that there are no unauthorised persons in the danger zone.
- The machine must not be operated while under the influence of alcohol or other drugs, or when tired.
- The machine must not be operated unless the operator has familiarised themselves with this instruction manual.
- The machine has been designed solely for making firewood.
- The machine must be placed in the transport position whenever it is moved. When transporting the machine on a public road, it must be equipped with additional lights.
- The operator is not permitted to modify the structure or operation of the machine or remove protective equipment.
- The operator must wear ear protectors, sufficiently tight-fitting work clothing and gloves, protective goggles and safety footwear. Ensure efficient ventilation and wear a respirator if necessary.
- Before starting up the machine, the operator must ensure that the machine and its guards are intact.
- When powering the machine with a tractor, the operator must ensure that the cardan shaft is undamaged and that the selected rpm range is correct. The machine must be attached to the tractor's lifting equipment during operation.
- Before starting up the firewood processor, the operator must ensure that all the control and safety devices are functional.
- When cleaning the machine or carrying out any maintenance, it must be disconnected from its power source.

Note! Do not leave a running machine unsupervised!

1.6. Noise and vibration

A-weighted maximum sound pressure at the working location 93.0 dB (L_{WA}) and sound power level 105.0 dB (LP_{pASmax}). The vibration values do not exceed 2.5 m/s².

1.7. Warning symbols

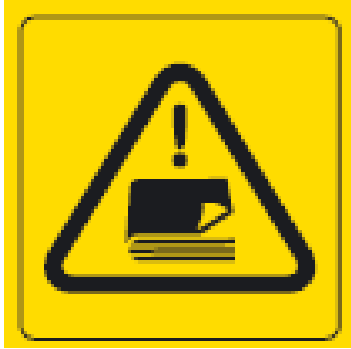

Read the machine's manual before operating the machine.



Wear eye and ear protection.



Wear safety footwear and work gloves.



Do not wear any loose items or clothing.



Always grab the piece of wood or log from the side.



Lifting point for a forklift.



Beware of moving parts.



Beware of the cardan shaft.



Beware of the saw chain.



Beware of the splitting blade.



Only one person may operate the machine.



Disconnect the power supply before any maintenance procedures.

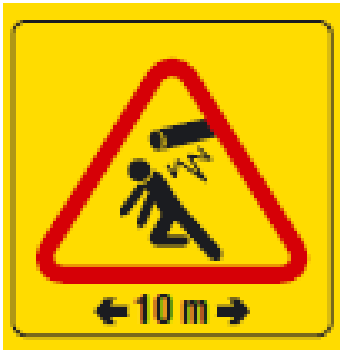

The danger zone around the machine is 10 metres.



Risk of crushing



The maximum permitted angle of the conveyor is 40°. Do not walk under the conveyor.



The maximum speed for the cardan shaft is 500 rpm.

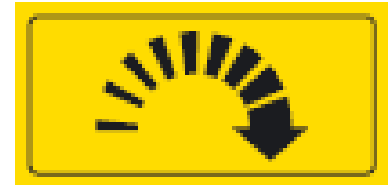

The rotation direction is in the direction of the arrow.



Hydraulic oil

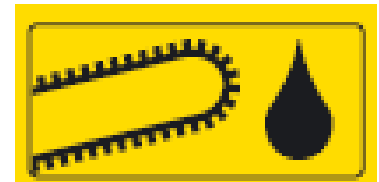

Saw chain oil



Danger zone



Lubrication point

2. Setting up the machine for operation and transport

2.1. Receipt inspection

Dispose of the machine's packaging materials in an environmentally friendly manner.

Check that the machine has not sustained any damage during transport, and ensure that all necessary parts are included in the package. In the event of any defects or damage, contact the retailer immediately.

Remove any cable ties and strap supports attached to the conveyors and saw bar for transport.

2.2. Main components of the machine

The main components of the Hakki Pilke Falcon firewood processor are presented in the figure below.

- A. In-feed conveyor
- B. Control unit
- C. Cutting and splitting unit
- D. Out-feed conveyor

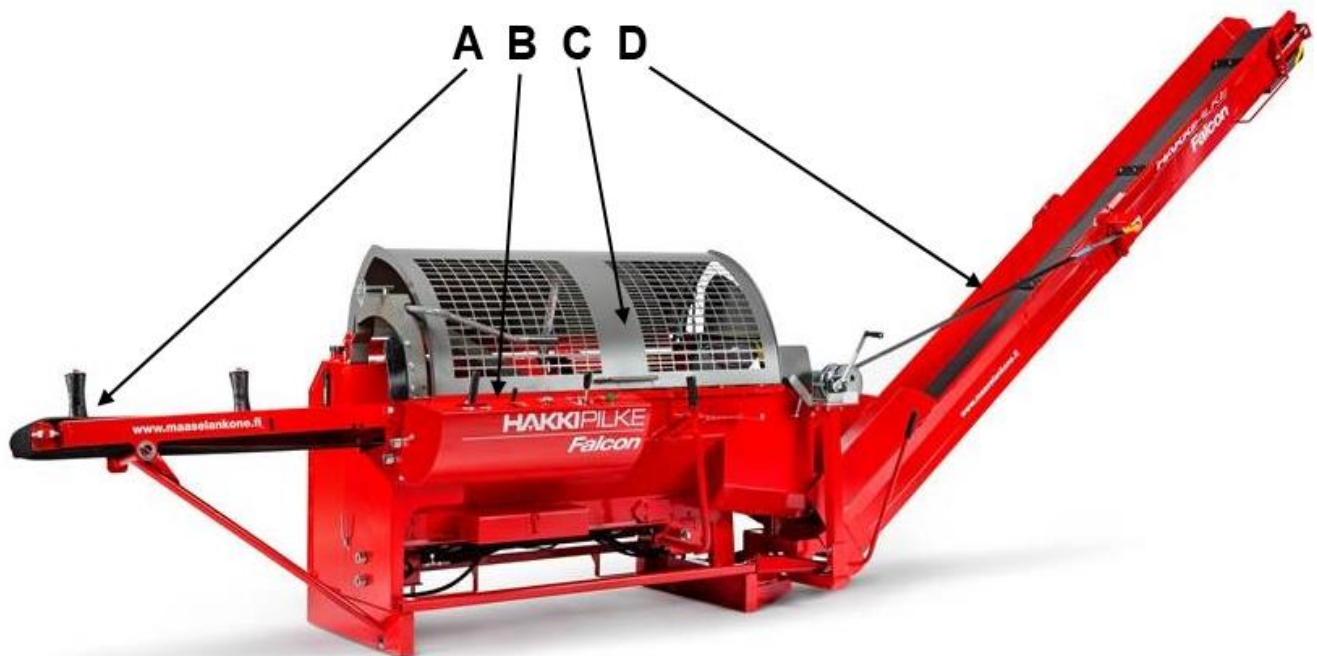

Figure 1

2.3. Arranging the machine for operation and transport

Before arranging the machine for operation and using it, ensure that the operating conditions, detailed in Section 1.4, are met and review the safety instructions in Section 1.5.

Note! Inspect and clean the machine before setting it up for transport!

Placing the in-feed conveyor in the operating or transportation position

Place the in-feed conveyor in the operating position as follows:

Ensure that sufficient room is available to lower the in-feed conveyor (approx. 2 m).

Remove the other end of support leg holder C from the lug (Figure 2).

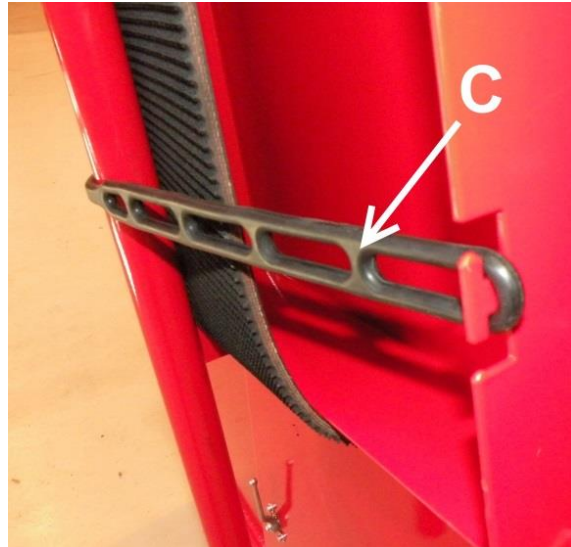

Figure 2

Release the lock (Figure 3) by removing pin A and turning (Figure 2) locking latch B out of its slot.

Note! At the same time, hold the end of the in-feed conveyor with your left hand!

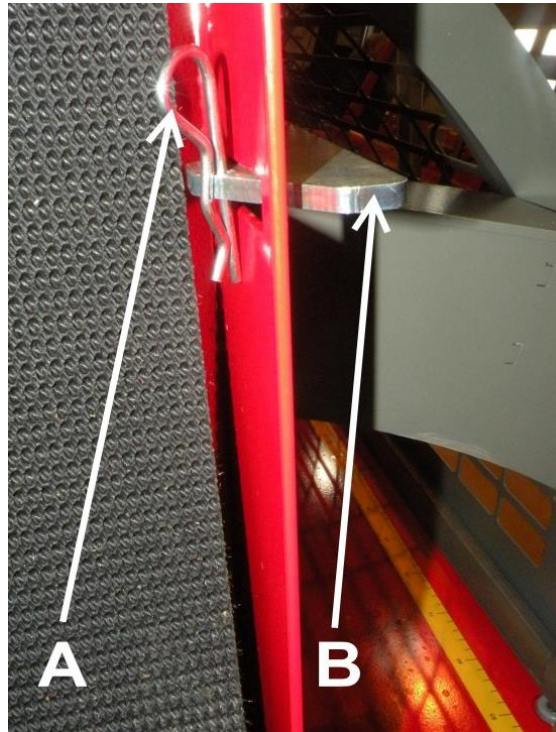

Figure 3

Lower the in-feed conveyor with your left hand while simultaneously using your right hand to guide support leg D
Hakki Pilke 35 Falcon rev. C

into slot E (Figure 4).

When placing the in-feed conveyor in the transport position, lift the conveyor to the upper position, turn locking latch B (Figure 3) into its slot and insert pin A (Figure 2). Use holder C to lock the support leg in place (Figure 2).

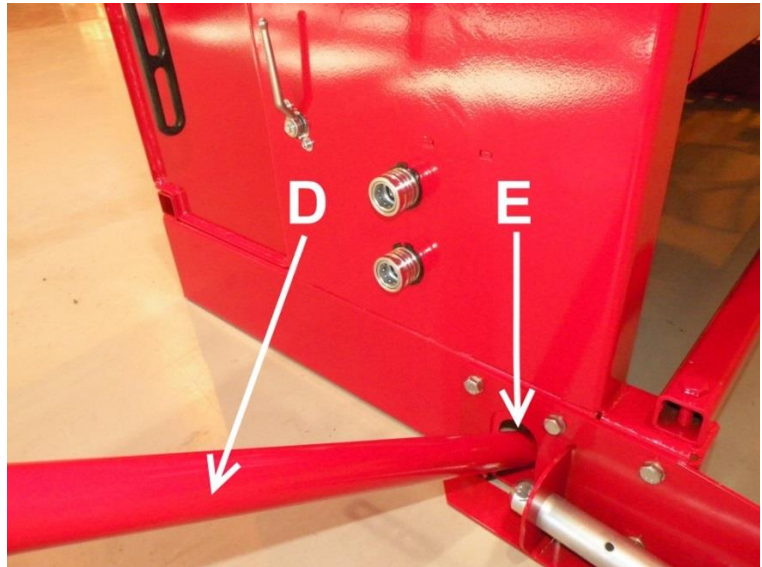

Figure 4

Placing the out-feed conveyor in the operating or transport position

Place the out-feed conveyor in the operating position as follows:

1. Ensure that there is sufficient room for opening the out-feed conveyor.
2. Turn off the machine and disconnect it from the power source.
3. Keep lock A (Figure 4a) open and lower the out-feed conveyor using a winch to its lowest position.

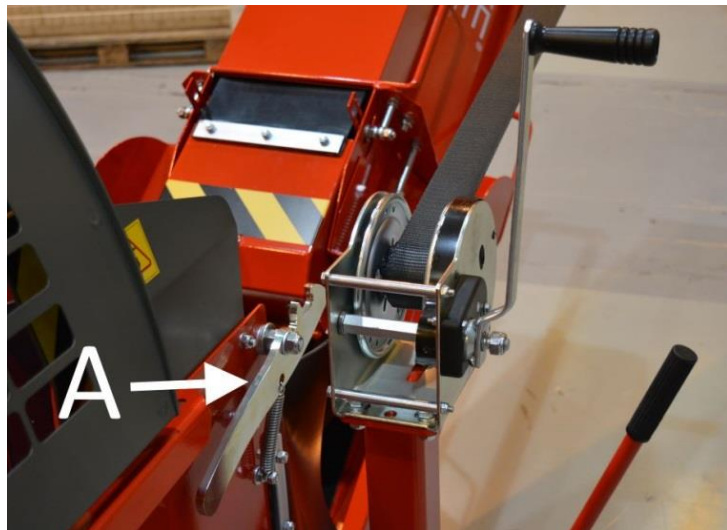

Figure 4a.

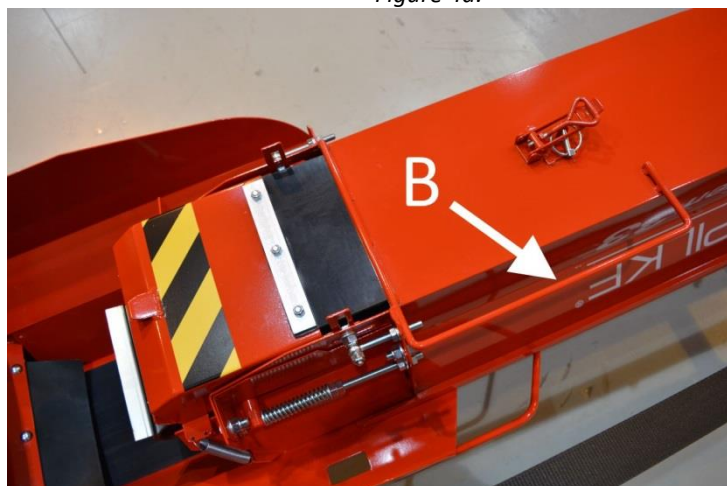

Figure 4b.

4. Turn the upper section of the conveyor into the operating position using handle B (Figure 4b).

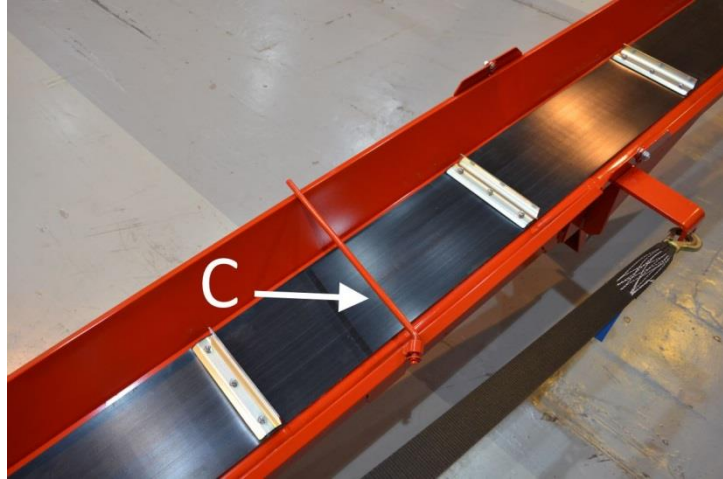

Figure 4c.

5. Turn transport position support bar C on the out-feed conveyor belt (Figure 4c) to the side.

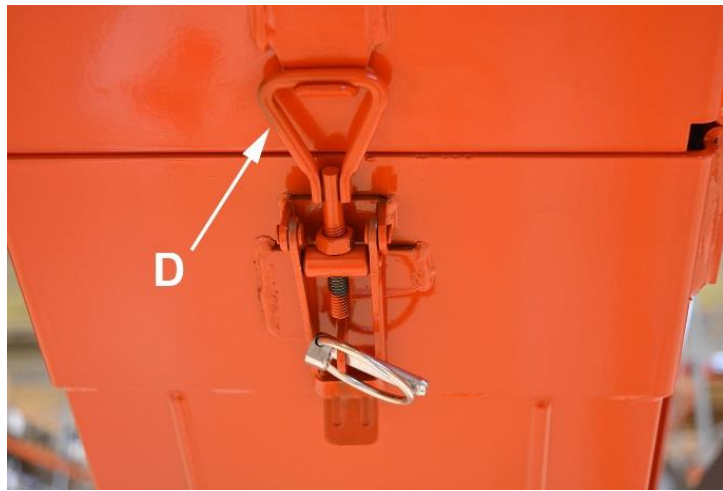

Figure 4d.

6. Use a winch to lift the conveyor to the desired angle (max 40°) and lock the upper section of the out-feed conveyor to the operating position using lock D (Figure 4d).

Place the out-feed conveyor in the transport position as follows:

1. Turn off the machine.
2. Release lock D (Figure 8) and lower the conveyor to the lowest possible position with the winch.
3. Turn support bar C (Figure 7) to a position over the belt, and turn the upper section of the conveyor onto the lower section using handle B (Figure 6).
4. Turn the conveyor to the middle position (only in machines with a pivoting conveyor). See Section 3.6.
5. Lift the conveyor with the winch until it locks into the raised position. Ensure that lock A (Figure 5) settles properly into place.

Note! Do not stand on the out-feed conveyor! Do not use the winch if the belt is worn!

2.4. Connecting the machine to a power source

Tractor-powered model

A tractor-powered firewood processor is connected to the tractor's three-point lifting device and cardan shaft.

Connecting the cardan shaft is a task for only one person. When connecting the machine to the tractor, there must be no one in the tractor cabin, so as to prevent any accidental contact with the controls. Check all the connecting devices of the tractor and the firewood processor before connecting them. Never use faulty equipment.

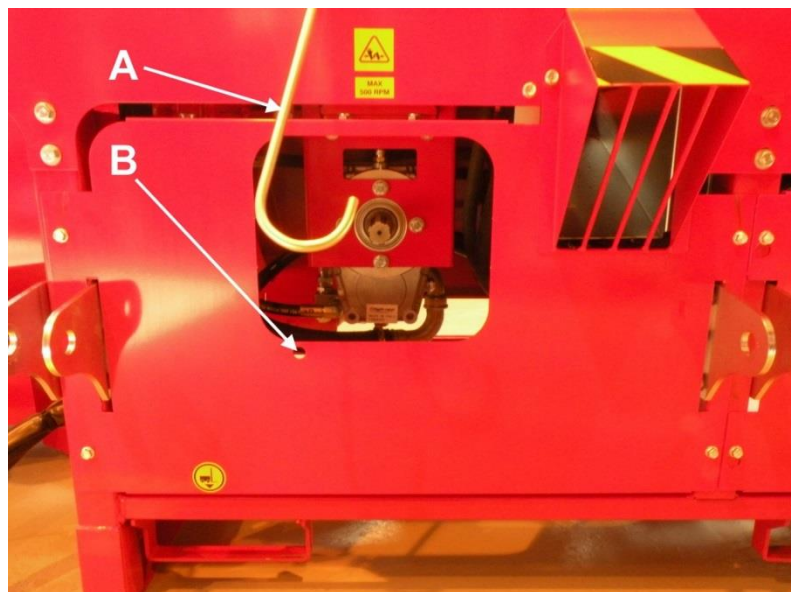

Figure 5

When using the cardan shaft, observe any instructions provided by the manufacturer of the shaft. The machine requires 7.5 kW of power, which must be taken into account with regard to the capacity of the cardan shaft. A suitable cardan shaft is of power class four. Make sure that the connected shaft is locked to the splined shaft of the multiplier gear. Connect the chain that prevents the turning motion of the protective cover to slot B (Figure 5). Hang the cardan shaft from hook A (Figure 5) when the machine is not being operated and it is disconnected from the tractor. Finally, ensure that all connections are safe and secure. Never use a damaged or unprotected cardan shaft.

Note! Tractor-powered machines must be attached to the lifting equipment of the tractor.

Electrically powered model

An electrically powered machine functions with a power of 7.5 kW. The IP rating of the electric motor is 55. The fuse must be a min. 16 A **type D fuse**. The electrical cable must be at least 5 x 4 mm², and it is connected to the socket in the electric motor (Figure 6).

The firewood processor can be activated with the green starter button on the front section of the machine. Use the red button to turn off the machine.

If the electric motor rotates in the wrong direction (i.e. the machine makes an abnormal noise and the hydraulic functions are inoperable), the current phase is incorrect.

We recommend using an extension cord that allows you to switch the current phase, or an adapter.



Figure 6

Note! If the extension cord does not have a phase switch, the electrical work related to changing the phase must only be performed by an electrician.

Note! Only connect the machine to a fault current protected socket.



Figure 7

2.5. Combustion engine model – Hakki Pilke Power Unit (accessory)

The Power Unit is connected to the tractor's three-point lifting device, but the cardan shaft is not needed as the combustion engine operates the pump directly.

Follow the engine manufacturer's instructions when using the engine. Always start the engine (Figure 7.1: A) unloaded and at slow speed. Ensure sufficient saw dust removal during operation to prevent the engine's filters from clogging and dust from accumulating on the engine's hot parts. If the combustion engine is equipped with a starter, always turn the main switch C to the OFF position after use. When using a separate fuel tank (B), fill up the tank according to the engine manufacturer's instructions.



Figure 7.1

2.6. Lifting and moving the machine

When moving the machine, make sure that the moving and lifting capacity of your tractor or forklift is sufficient for the weight of the machine. Only lift the machine by the indicated lifting points (Figure 8) or with the lifting equipment of the tractor.



Figure 8

When connecting the machine to the tractor's lifting equipment, the tractor cabin must be free of people in order to prevent any accidental contact with the controls. Check all the connecting devices of the tractor and the firewood processor before connecting them. Never use faulty equipment. The pins that are used to connect the pushbars and drawbars to the machine must be of the correct size, and the appropriate locking pins must be used to secure them.

The machine must be placed in the transport position whenever it is moved. Exercise extreme caution when moving the machine in the operating position. Always lower the machine to the ground when you stop.

Note! Incorrect lifting may cause a hazardous situation or damage the machine.

2.7. Additional hydraulics connections (accessories)

Using the quick couplings of the additional hydraulics

Connect the additional hydraulics (HakkiLift log lifter or HakkiFeed log table separator) by inserting the hydraulic hoses of the accessory into quick couplings **A** (red) and **B** (black) (Figure 9). Use the quick couplings with control lever **B** (Figure 11).

Note! Only connect official Hakki Pilke accessories to the machine's quick couplings!



Figure 9

Using hydraulic in-feed rollers and HakkiFeed log table quick couplings

Hydraulic in-feed rollers and HakkiFeed log tables can be connected in series with the machine's in-feed conveyor. In this case, the in-feed rollers function automatically in synchronisation with the in-feed conveyor when logs are being fed in with lever **D** (Figure 11).

Connect the in-feed roller hoses to quick couplings **C** (red) and **D** (black) (Figure 10). Turn valve **E** down to open it (ON position) and enable the oil to flow into quick couplings **C** and **D** in Figure 10. Make sure that the rotation direction of the rollers is the same as the conveyor's direction. If necessary, switch the order of the hoses in quick couplings **C** and **D**.

Note! Valve E must always be turned to the right (OFF) whenever quick couplings C and D are not in use (Figure 10)!

Note! Only connect official Hakki Pilke accessories to the machine's quick couplings!



Figure 10

3. Operating the machine

3.1. Controls and functions of the machine

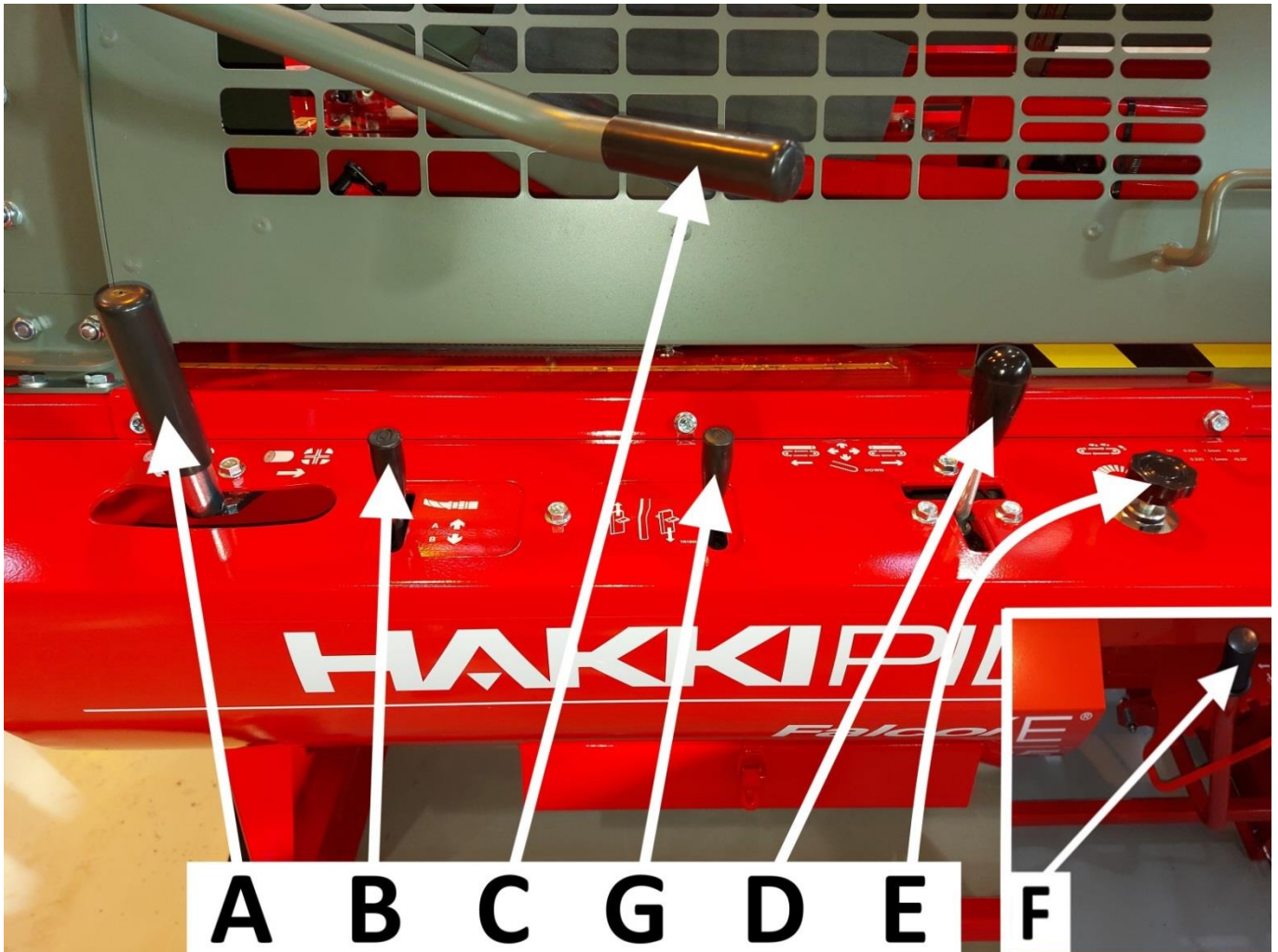

Figure 11

Names and functions of the controls (Figure 11):

- A. Splitting cylinder control lever
 - Pushing the lever to the left returns the splitting cylinder to the initial position.
 - Pushing the lever to the right makes the splitting cylinder perform the splitting motion.
- B. Control valve for an auxiliary device, such as a log lifter, (accessory).
- C. Wood gripper handle. With the handle, wood can be pressed against the table during sawing in order to make cutting the wood as safe and stable as possible.
- D. Control lever for the saw bar and out-feed conveyor.
 - Saw bar up/down: push the lever forward/backward
 - Input conveyor control right/left: push the lever to the upper right and upper left
- E. Output conveyor speed control
 - Turning the knob anti-clockwise increases the output conveyor belt's rotation speed.
 - Turning the knob clockwise slows down and eventually stops the belt rotation.
- F. Splitting blade height adjustment lever.
- G. Control valve for splitting blade height adjustment (accessory, replaces control device F)

3.2. Before using the machine

A test run and functional test must always be carried out before the actual operation of the machine. Both the test run and testing can only be performed by a person who has studied the machine's manual.

Before the test run, all the components of the firewood processor must be checked. If any faults or wear and tear that may affect the safe use of the machine are discovered, the processor must not be used until the faulty or worn component is replaced and safe use can be ensured.

Before using the machine, the operator must ensure that

- the machine has not sustained any damage
- the machine's operating environment is in accordance with Section 1.4
- the machine is positioned on a solid foundation
- no unauthorised persons are within the machine's danger zone
- all guards and safety devices are in place and functional
- opening the splitting and cutting guard stops the machine's hazardous functions (see items 3.3, 9 and 13 in Section 14)
- the hydraulic hoses, connectors and pipes are undamaged. The hydraulic hoses and pipes must be replaced if they exhibit tears or depressions, if they leak, or if the surface layer of the hydraulic hose has worn all the way down to the supporting weave.
- the machine does not leak oil
- the machine functions properly (Section 3.3)

Note! Do not use the machine if the requirements listed above are not met!

3.3. Performing a test run on the machine

1. Check that the guard for the firewood processor's cutting and splitting section is down.
2. Check that the in-feed and out-feed conveyors are in the operating position.
3. Ensure that the splitting groove is empty.
4. Make sure that you are familiar with the functions of the machine's controls. If necessary, refer to Section 3.1.
5. Activation.
 - a. Tractor drive: Start the tractor and connect the output, starting with a slow speed and increasing the speed to a maximum of 500 rpm.
 - b. Electrical drive: Connect the cable to the socket of the firewood processor, start the machine by pressing the start button and wait until the electric motor operates at full speed.
6. Activate the machine's splitting motion by lowering the saw bar fully into the lower position and lifting it back up using lever D (Figure 11). The splitting motion must be normal. The splitting motion can also be activated by pulling lever A to the right (Figure 11).
7. Do the following to ensure that the saw chain lubrication functions automatically: (If necessary, see Section 4.12.)
 - a. Use lever D (Figure 11) to perform a few sawing motions without any actual logs.
 - b. Turn off the machine and disconnect it from the power source.
 - c. Open the guard and ensure that the saw chain has been supplied with oil and that the chain oil hose has filled with oil and contains no air bubbles.
8. Ensure that the saw chain starts running when you lower the saw bar by about 2 cm using lever D (Figure 11).

Note! In cold weather, the saw valve shaft may be sluggish at first, which means that the saw bar must be driven to the bottom position a couple of times for the saw chain to run.

9. Start the splitting cycle and stop it by opening the cradle guard of the cutting and splitting section.

10. Ensure that the splitting blade returns to the initial position (in the middle of the splitting motion) also by pushing lever A (Figure 11) to the left.
11. Test run the feed and return motion of the in-feed conveyor using lever D (Figure 11) by pushing the lever to the upper right (belt runs to the right) and upper left (belt runs to the left).
12. Start the out-feed conveyor by using control E (Figure 11) to adjust the speed to an appropriate level for the conveyor.
13. Ensure that the guard does not open when the saw bar is spinning.
14. Ensure that the splitting motion or saw blade cannot be activated with the guard open.

If a fault occurs during the test run, determine the cause of the fault and take remedial action as deemed necessary. The machine must be shut down and disconnected from the power source for the duration of both the diagnostics and repairs.

Note! When the temperature of the hydraulic oil is < 5°C, the machine must be allowed to idle until the oil temperature rises to at least > 10 C° before starting operation.

Always lift open the machine's safety cage when the machine is not used to saw/split firewood and when loading the log table, for example!

Note! Do not leave a running machine unsupervised!

3.4. Feeding and sawing wood

The in-feed conveyor feeds the wood to be processed into the machine. Feed wood into the machine using control lever D in Figure 11 of Section 3.1.

When feeding wood into the machine, make sure that it does not present a risk of your clothes, hands or other parts getting caught in the machine, for example, due to the shape of the log. Do not use your hand to guide the log into the cutting section. Adjust the wood measuring device to the desired length and make sure that the speed of the out-feed conveyor belt is suitable by adjusting it.

1. Choose the log to process. Note that the maximum log diameter is 35 cm. The knottiness and shape of the log can increase the diameter.
2. Use the in-feed conveyor to feed wood into the cutting section by pushing lever D in Section 3.1 (3.111) to the upper right position. You can cancel the feed by pushing lever D to the upper left position.
3. Once the log stops for cutting in the mechanical measuring device, lock the log in place with the wood press by pressing handle C of the press (Figure 11) downward.
4. Cut the log by pulling lever D back, which activates the saw chain and lowers the saw bar (Figure 11).
5. Return the saw bar to the raised position by pushing lever D (Figure 11) forward, **which automatically activates the splitting function.**

**Note! You cannot use the machine to saw during the splitting motion of the splitting beam!
Sawing is allowed during the return motion of the splitting beam.**

Placing logs on the in-feed conveyor

We recommend the use of auxiliary devices, such as the HakkiFeed 422 timber deck. If a timber deck is not attached to the machine, the maximum allowed log length is 4.5 m. Always lift and place wood on the in-feed conveyor in a safe manner that does not put the operator in danger.

Note! Placing logs directly on the in-feed conveyor with a loader is strictly prohibited.

Note! Ensure that the log's centre of gravity stays on the conveyor.

Sawing the last log

When sawing wood, the second to last piece should be sawn in such a way that the remaining piece is of a sufficient length. This ensures that the log will stay firmly under the log press and that the sawing will be steady and safe. Drive the last piece of wood directly into the splitting section, and start the splitting process with control lever A or lever E (Figure 11).

3.5. Log splitting

The splitting beam performs the splitting motion automatically whenever the saw bar is lowered all the way down using lever E (Figure 11) and raised back up again. In other words, the splitting motion starts automatically when the log is dropped into the splitting groove after cutting and the saw bar is lifted back up.

In addition to this, control lever A (Figure 11) can be used to activate the splitting by pushing the lever briskly to the right and returning it to the initial position. This function is useful, for example, when the last log to be split has been driven into the splitting groove. In this way, the operator does not have to unnecessarily move the saw bar into the lower position. Instead, the splitting function can be activated much faster using this lever.

The machine's splitting motion can be interrupted by pushing control lever A to the left (Figure 11). **The splitting can also be halted by raising the machine's guard when the saw bar is in the upper position.**

Re-splitting or splitting without cutting

1. Raise the protective cover of the cutting and splitting channel.
2. Place the log you want to split in the splitting groove.
3. Close the cutting/splitting guard.
4. Activate the splitting using lever A (Figure 11).

The above procedure can be used to split wood without cutting it, as necessary.

3.6. Using the out-feed conveyor

The belt of the Hakki Pilke Falcon firewood processor's out-feed conveyor is driven by a hydraulic motor. To change the speed of the belt, use adjuster F (Figure 11). The optimal speed for the cleaning out-feed conveyor belt can be determined by trying different settings. The split logs should only just pass over the plate. The separation plate can be adjusted with adjustment screws B in Figure 25.

The out-feed conveyor can be adjusted laterally and vertically. The following describes how the conveyor can be turned laterally by using turning lever A and handle B (Figure 12):

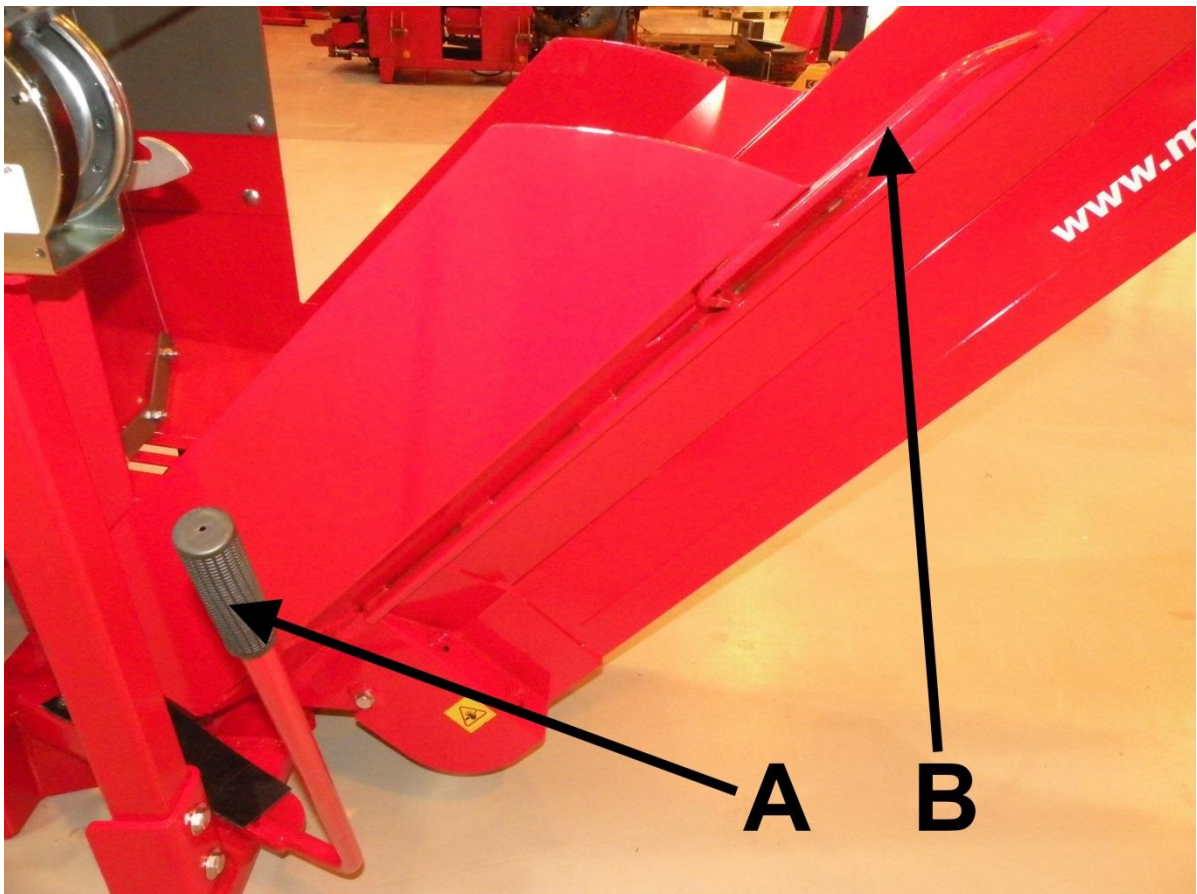

Figure 12

Release the lock of the conveyor by pushing lever A towards the conveyor, and turn the conveyor to the desired position with handle B (Figure 12).

The maximum operating angle for the out-feed conveyor is 40°. The maximum angle is indicated on the label (Figure 13) and the instructions attached to the out-feed conveyor.

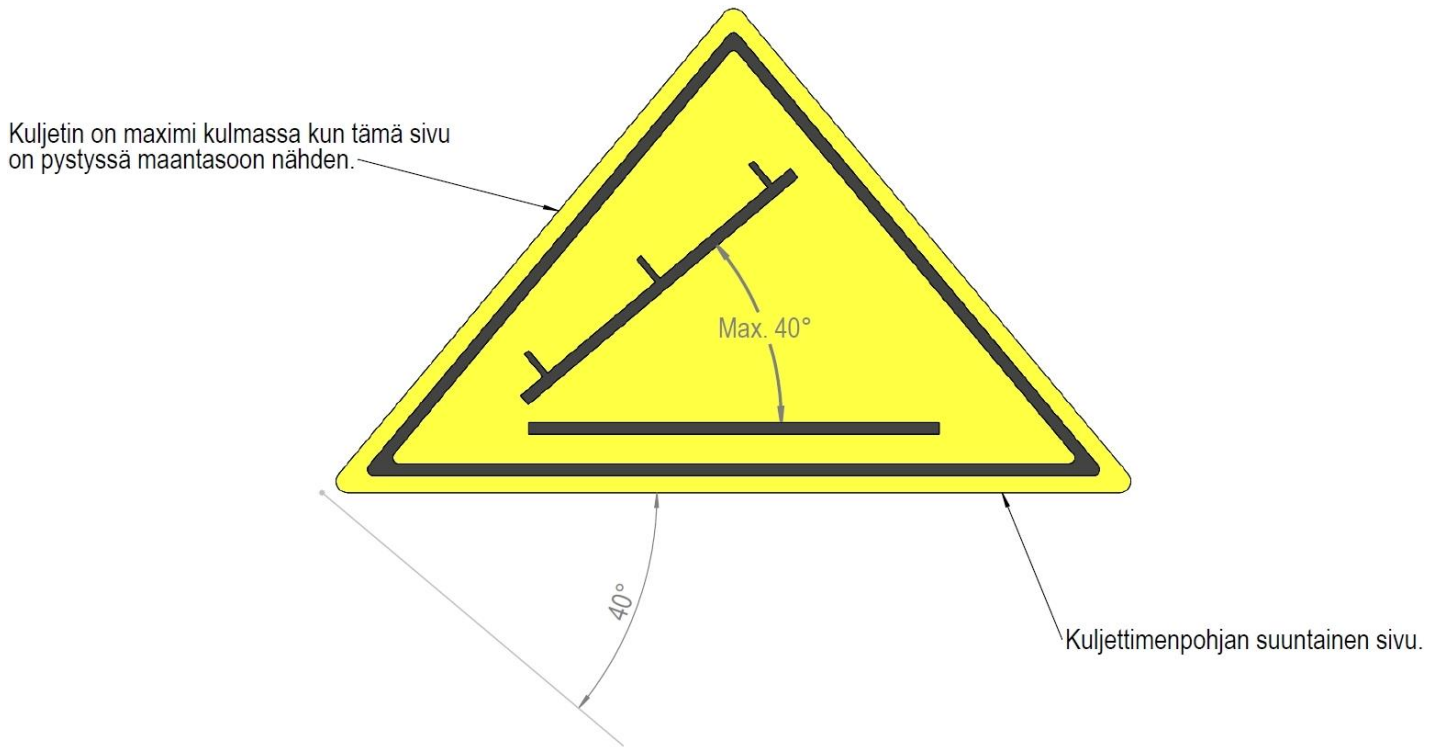

Figure 13

If the conveyor is jammed for any reason, its running speed must be set to zero and the machine must be shut down before removing the cause. There must be at least 50 cm between the end of the out-feed conveyor and the pile of processed firewood.

Note! The operator must ensure that the distance between the debris discharge opening and the pile of debris that accumulates under it is at least 20 cm.

3.7. After use

1. After you have finished making firewood, stop the out-feed conveyor, shut down the machine and remove the firewood from the splitting channel and conveyor.
2. Check that the machine has not been damaged.
3. Place the out-feed conveyor into a position that allows the conveyor and firewood processor to be moved safely off the processed firewood.
4. Clean the machine.

If you will not be using the firewood processor for a while, do the following:

5. As necessary, use your tractor's hydraulics or a forklift to hoist the firewood processor and carefully move it to a location where you can place the in-feed and out-feed conveyors as well as the working platform into their transport and storage positions.
6. Place the conveyors into the transport and storage position.
7. Clean the machine and carry out any maintenance.
8. Store the machine according to the instructions in Section 4.14.

4. Maintenance and adjustment of the machine

The machine must be disconnected from its power source before maintenance, adjustment, replacement or cleaning procedures. Only use spare parts that are supplied by the manufacturer or your retailer. If the guards of

the machine have to be removed for maintenance, they must always be reattached before the machine is activated. After maintenance and adjustment measures, the machine must be test run according to the instructions in Section 3.3.

4.1. Disconnecting the machine from its power source

Tractor-powered model

Turn off the tractor and disconnect the machine's cardan shaft from the tractor.

Electrically-powered model

Turn off the machine and disconnect the power cable from the socket.

PowerUnit combustion engine-powered model. Switch off the combustion engine and turn it in the off position. Be sure to also turn the main power switch in the OFF position.

Ensuring that the machine is inactive

Once you have disconnected the machine from its power source, always ensure that the machine is completely inactive before performing any other measures!

4.2. Adjusting the log length

The Hakki Pilke Falcon firewood processor is equipped with a mechanical log measurement device with an incremented adjustment value of 25–50 cm.

1. Open the machine guard.
2. When the wood limiter is in the splitting position, set it to the desired length by removing cotter pin B (Figure 14) in the limiter's locking pin and by pulling out locking pin A. Lock the limiter plate C in the desired position. Re-insert locking pin A and cotter pin B.

Note! Turn the limiter plate to the correct position according to the thickness of the log. (See Figures 18 and 19).

Note! Limiter plate C features holes at different intervals, which means that the fine tuning can be conducted with the suitable combination.

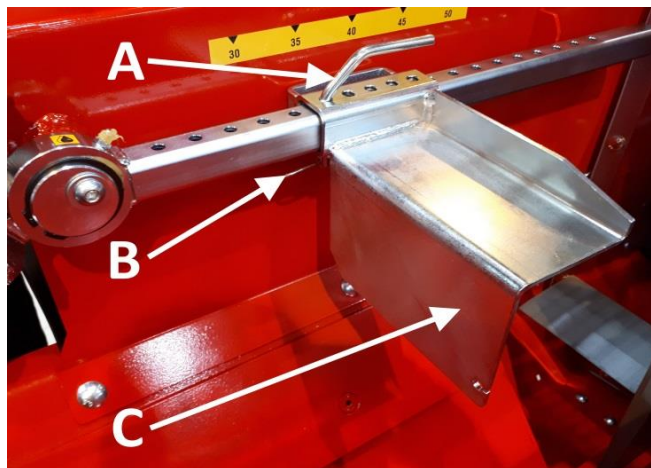

Figure 14: Measuring device position for small logs less than 25 cm in diameter.



Figure 15: Measuring device position for large logs of more than 25 cm in diameter

4.3. Height adjustment of the splitting blade

The splitting blade can be controlled mechanically by moving control lever F (Figure 11 and 20) up or down. The splitting blade can be lifted by moving lever F to the left and vice versa. Logs should always be as centred as possible when passing the blade in order to keep the size of the firewood consistent.

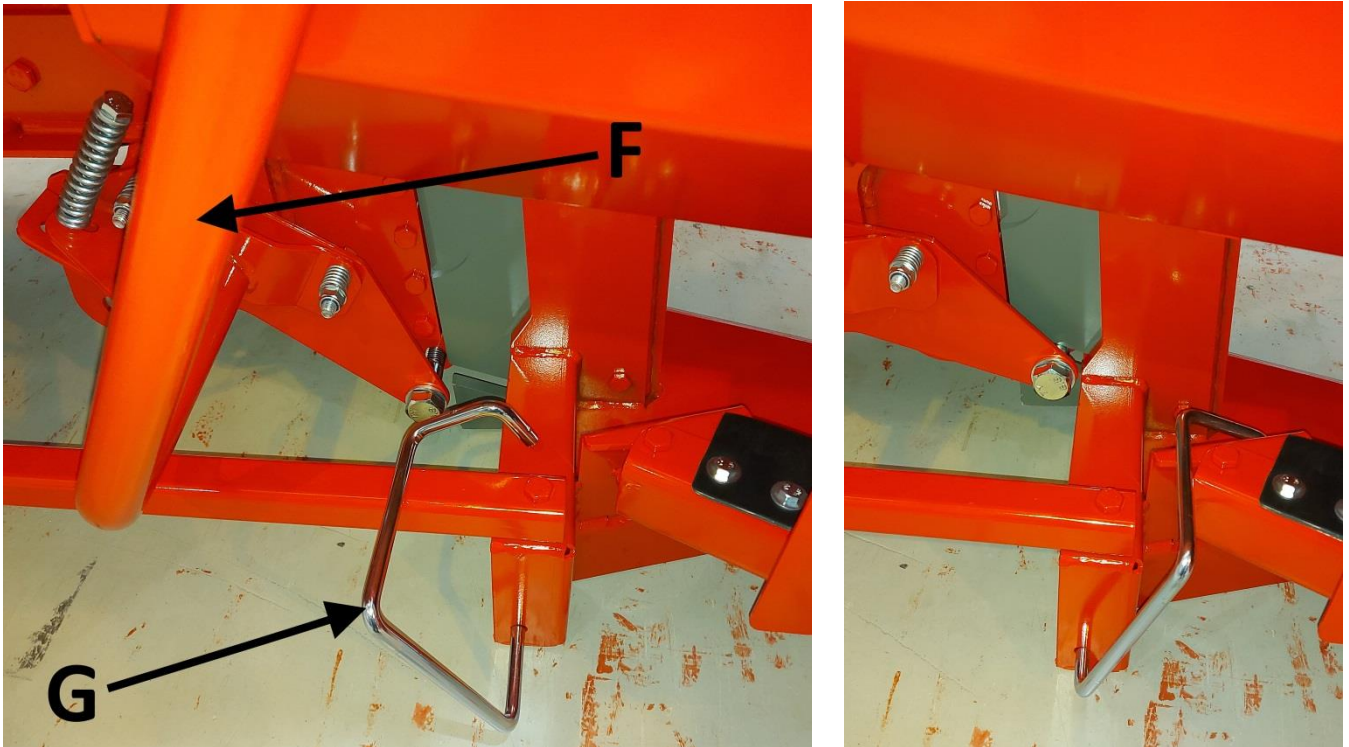

Figure 16 (The splitting blade is detachable on the left and locked on the right)

The blade can be driven to the lowest position in one go by raising the blade and clearing the space under the blade of firewood (Figure 20, right). The machine guard must be opened or the machine must be disconnected from its power source for the duration of cleaning or blade replacement so that the splitting and sawing functions are inoperable.

4.4. Replacing the splitting blade

Exercise extreme caution when handling the blade, and wear protective gloves.

1. Remove the firewood under the splitting blade and turn blade lock G to the left and pull it outwards to enable the splitting blade to be moved to the lowest position for detachment.
2. Move the splitting blade to the lowest position using lever F (Figure 11), as shown in Figure 20 on the left.
3. Open the guard and lift the splitting blade out of its slot.
4. Install a new splitting blade by reversing the above steps.

4.5. Opening the maintenance hatch and adjusting the length of the splitting stroke

1. Run the input belt to a position where the fastening groove is facing upwards.
Start the splitting function and turn off the machine when the splitting slide is out of its starting position. Disconnect the machine from its power sources.
2. Remove log press locking pin **A** and pin **B** (Figure 17). Remove the entire log press as well as the fastening bolts (5 pcs) and detach the guard.
3. If necessary, move the input belt and the dust guard out of the way by disconnecting the fastenings.
4. Adjustment screw **C** defines the stroke length of the splitting cylinder, i.e. the phase in which the splitting valve turns from the splitting position to the reverse position (Figure 18). If the stroke is too short, for example (i.e. the splitting cylinder does not go sufficiently close to the splitting blade), rotate adjustment screw **C** further in relation to plate **D** and vice versa.
5. Valve **F** (Figure 19) stops the cylinder after a splitting motion. The initial position cannot be adjusted.

Note: splitting lever **G** moves the same splitting bar as splitting activation lever **E**. (Figure 18)

The extreme positions of the splitting valve can be limited with bolts **H** and **I** (Figure 18 and Figure 19). The bolt adjustments should not be changed. Instead, worn bolts should be replaced with new ones!

Note! The covers and guards must be reattached after maintenance.

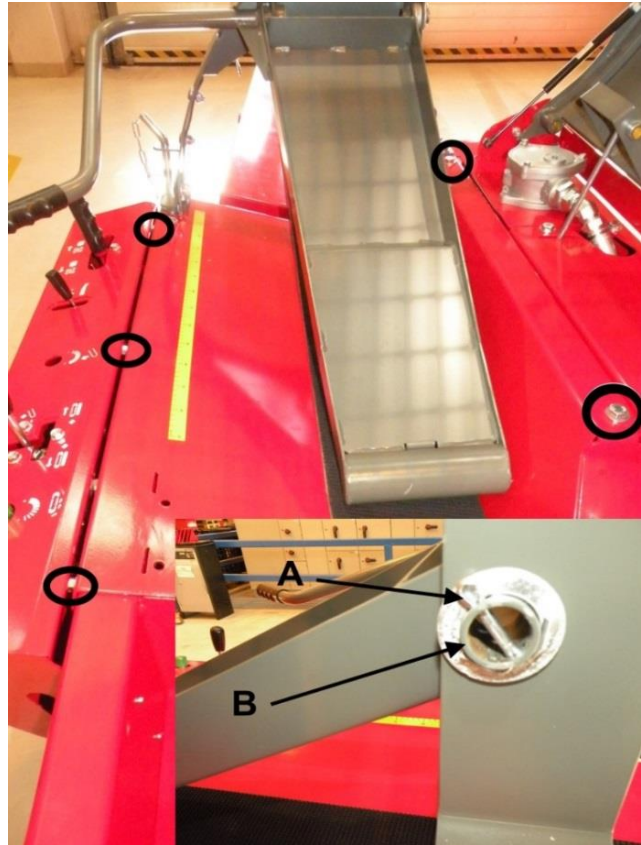

Figure 17

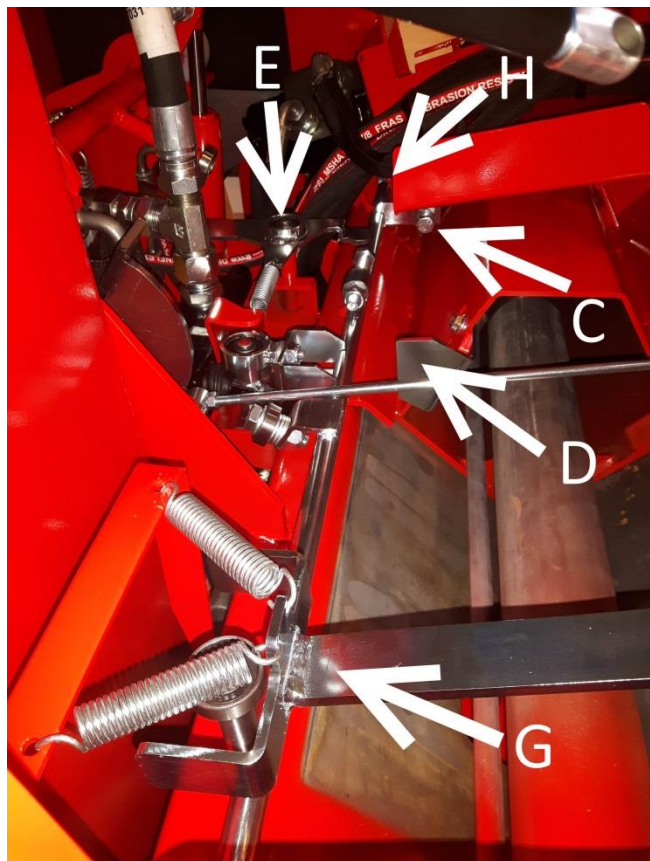

Figure 18

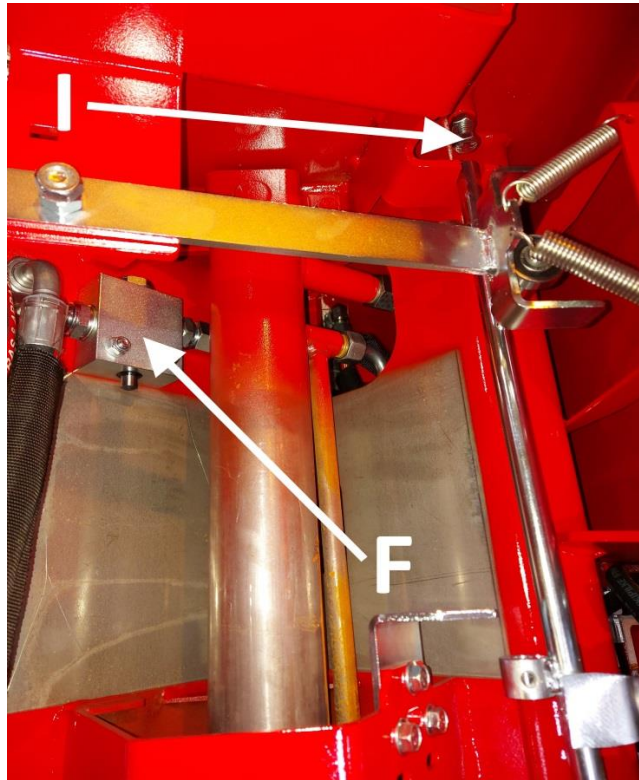

Figure 19

4.6. Out-feed conveyor belt adjustment and cleaning out-feed conveyor

The tightness and alignment of the out-feed conveyor's belt can be adjusted using nuts A in Figure 20 (2 pcs). Loosen adjustment nut A on the side to which you wish the belt to run. Do not tighten the belt excessively to prevent the spring being compressed.

The Hakki Pilke Falcon firewood processor features a cleaning conveyor that separates debris and sawdust from the processed firewood.

The following things significantly affect the operation of the debris removal device: the angle of the out-feed conveyor, the speed of the belt and the distance of separation plate C (Figure 20) from the upper roller of the conveyor. In other words, the debris separation result is better the steeper the angle (however, no more than 40 degrees), the lower the speed and the longer the distance between separation plate C and the upper roller. The distance of separation plate C is optimised at the factory in conjunction with the testing of the machine. However, the adjustment can be changed, if necessary.

Debris removal can also be deactivated by turning the mechanism under the conveyor and locking it in place with the designated latch.

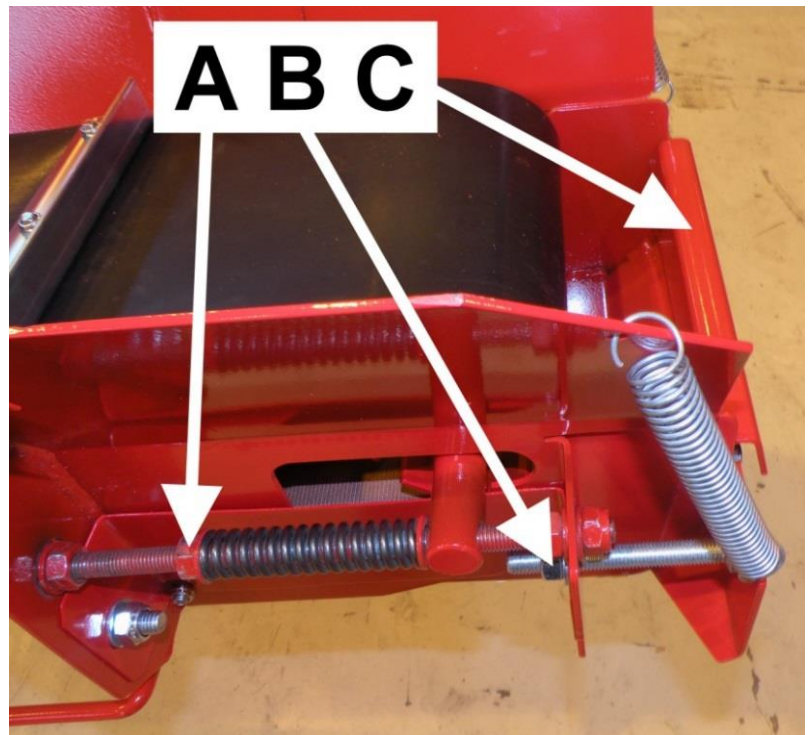

Figure 20

Cutting blade and drive end

If the cutting blade of the machine does not penetrate the wood properly or the cut is skewed, the blade chain is most likely blunt. It is a good idea to keep a replacement chain handy, so that you do not need to interrupt your work to sharpen the chain.

Replacing and tensioning the saw chain

Replace the saw chain as follows (Figure 21 *Virhe. Viitteen lähdettä ei löytynyt.*):

1. Turn off the machine and disconnect it from its power source.
2. Open the guard.
3. Loosen the flange bolts B.
4. Fully loosen the adjustment screw A for blade chain tension.
5. Remove the old saw chain.
6. Install the new saw chain and ensure that the cutting teeth come first in relation to the rotating direction.
7. Lift the saw bar from the front section to tighten the chain as you are attaching the bolts.
8. Tighten the saw chain with adjustment screw A, and tighten the fastening bolts.

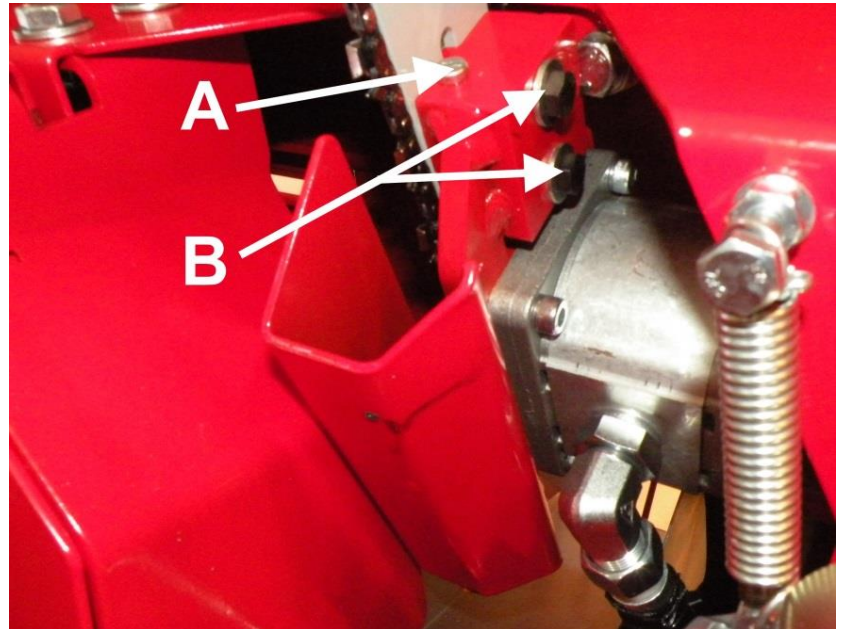

Figure 21

To check the tension of the saw chain, wear protective gloves and pull the lower edge of the chain. The tension is correct if you can pull out three to four teeth of the chain **into full view** by applying moderate force.

Note! Use protective gloves when handling the saw!

Replacing the saw bar

Replace the saw bar as follows (Figure 22 **Virhe. Viitteen lähde ei löytnyt.**):

1. Remove the saw chain according to steps 1–5 of Section 0 “Replacing and tightening the saw chain”.
2. Remove flange bolts (2 pcs) and remove the flange fastening plate A.
3. Remove the saw bar from the groove.
4. Place the new flange against gear wheel B, twist it into the groove and loosely attach the flange bolts and fastening plate A.
5. Attach and tighten the saw chain according to steps 6–8 of Section 0 “Replacing and tightening the saw chain”.

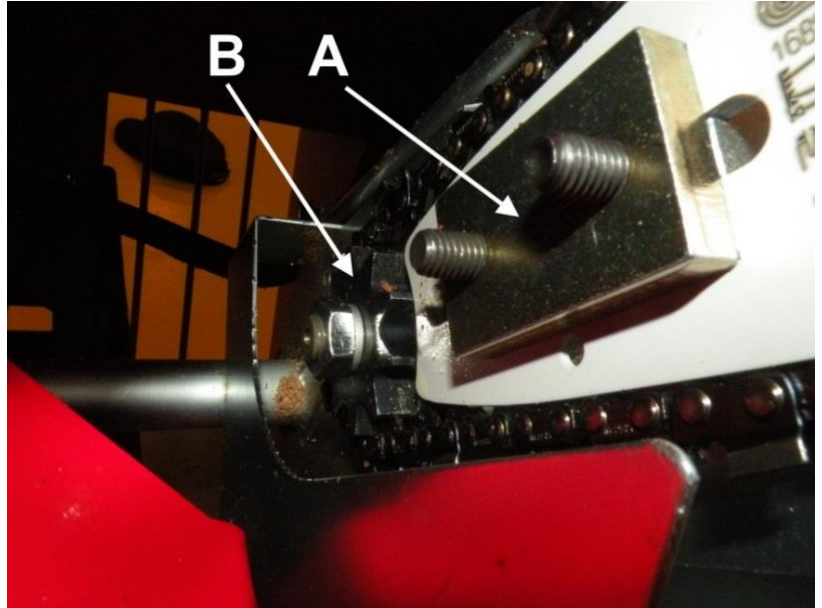

Figure 22

4.7. Changing the oil

Change the hydraulic oil of the fire-wood processor as follows (Figure 23 and Figure 24):

1. Shut the machine down and disconnect it from its power sources.
2. Open filler cap A of the hydraulic oil tank (this will allow the oil to drain more easily).
3. Open drain plug B and drain the oil into a suitable container.
4. Open the cover of hydraulic filter C and replace the filter.
5. Tighten plug B firmly, and fill the tank with fresh oil (approx. 65 litres). Ensure that the oil type matches the operating temperature! (See the maintenance table.)
6. Finally, ensure that the oil level settles at the halfway point of gauge D.

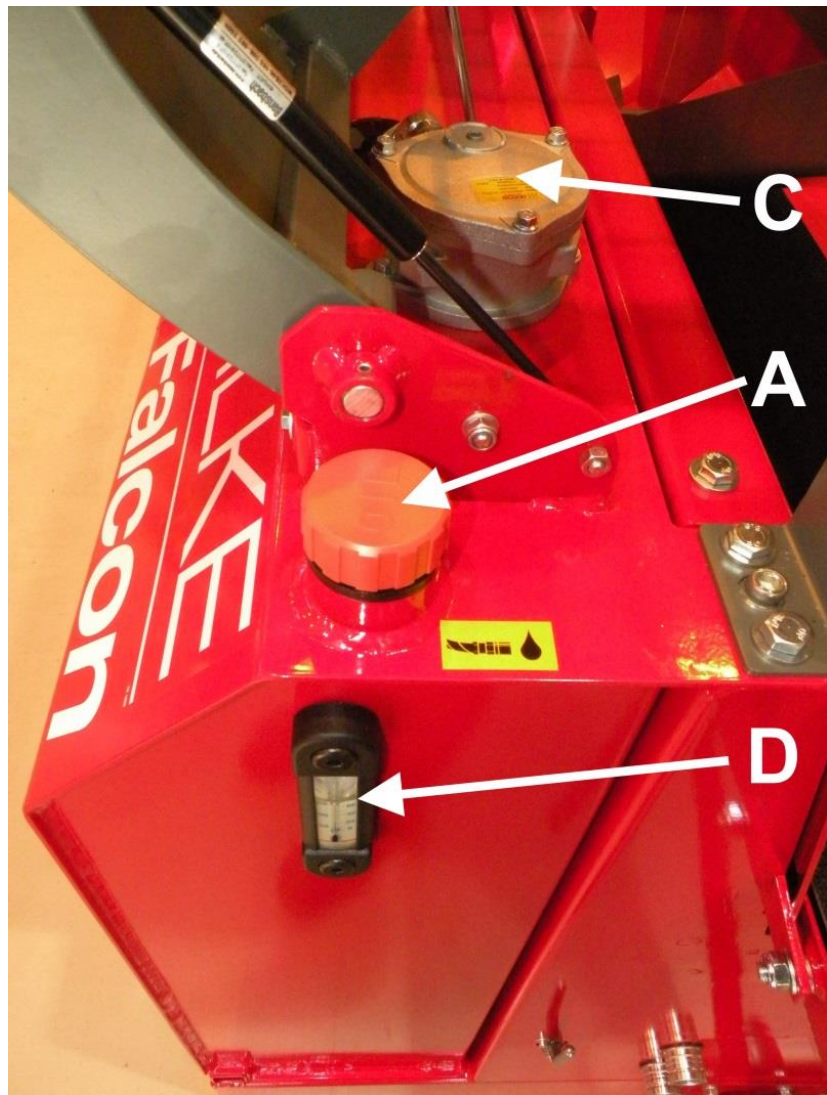

Figure 23

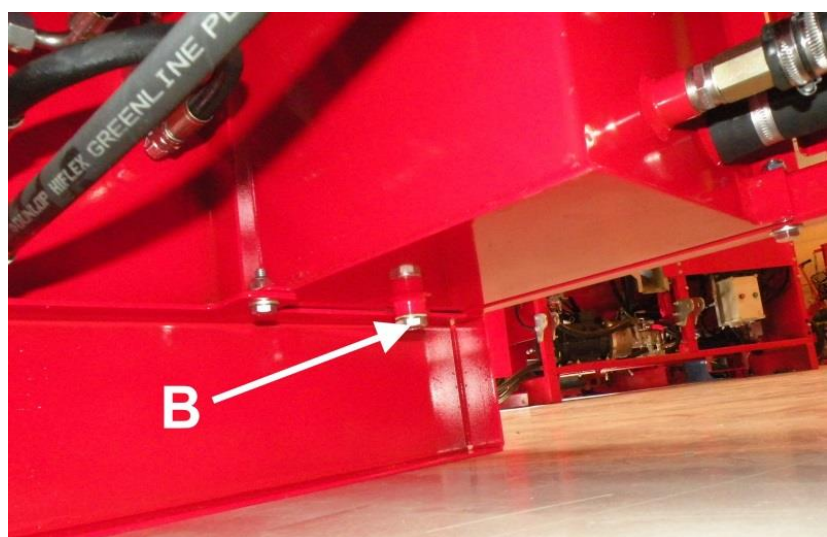

Figure 24

4.8. Changing the oil of the multiplier gearbox

Change the multiplier oil as follows (Figure 25):

1. Open filler cap A (this will allow the oil to drain more easily) and drain cap C and drain the oil into a suitable container.
2. Close drain cap C and open inspection cap B.
3. Add appropriate oil into the angle transmission through filling hole A, until the oil surface is level with the level inspection hole B.
4. Finally, close caps A and B.

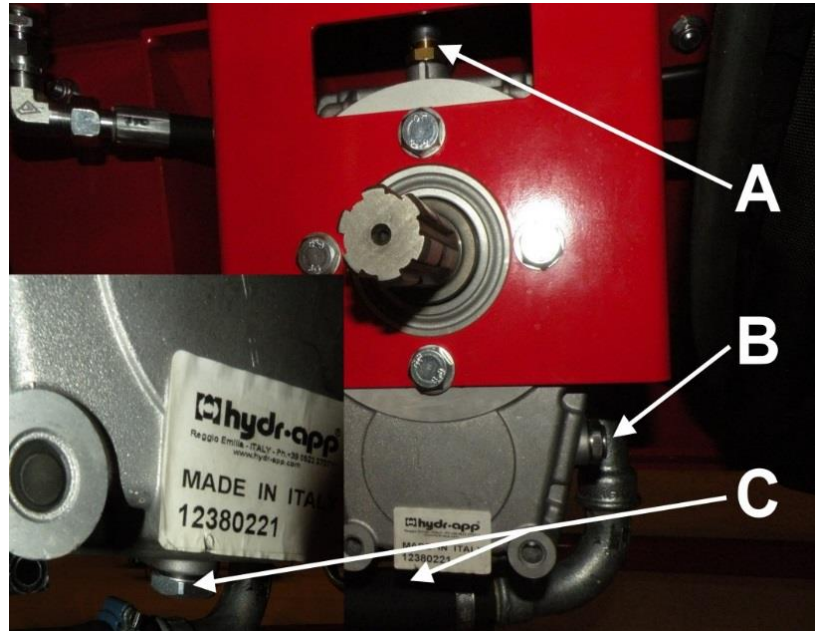

Figure 25

4.9. Conveyor maintenance

Replacing and tensioning the in-feed conveyor belt

Replace the in-feed conveyor belt as follows:

1. Shut the machine down and disconnect it from its power sources.
2. Raise and lock the in-feed conveyor into the transport position. (See Section 2.3).
3. Move the belt joint to a suitable height.
4. Disconnect the joint by using, for example, pliers to pull out pin A (Figure 26) holding the joint together.
5. Remove the old belt.

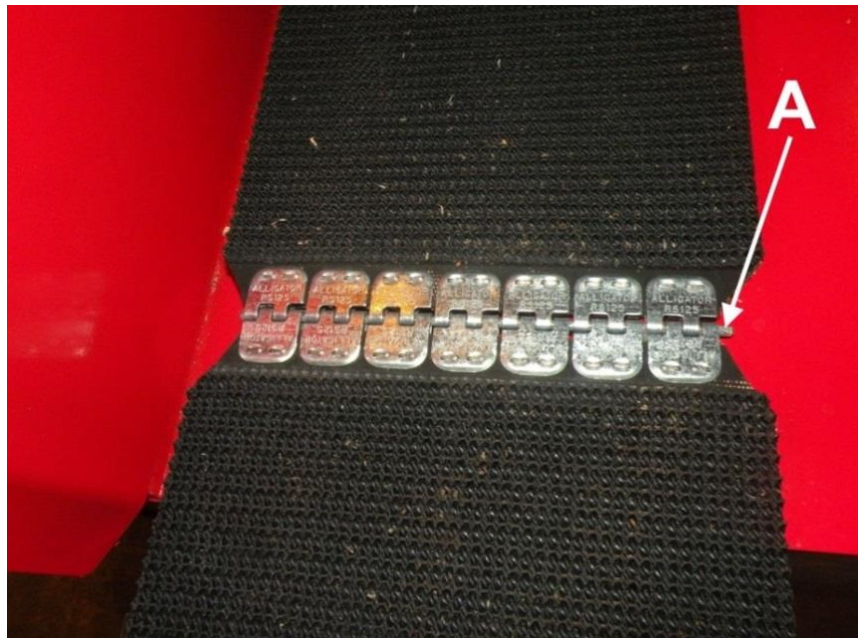

Figure 26

6. Insert the new belt from the side of the in-feed conveyor's drive roller through opening B (Figure 27), until you can pull the belt out from other end C (Figure 28). Note! If necessary, remove the guard of the in-feed conveyor in accordance with the instructions in Section 4.5.
7. Lead the rest of the belt under the log press, around the rear roller and, finally, behind the conveyor.
8. Connect the joint by inserting pin A (Figure 26) into the joint.
9. Turn the conveyor back to the operating position and tighten the belt. Use adjustment nuts D (Figure 29) to adjust the belt.

The belt is at the correct tension when its middle section is raised approx. 5 cm when the conveyor is in the operating position. An excessively tight belt may be damaged more easily, and it places unnecessary strain on the bearings of the conveyor.

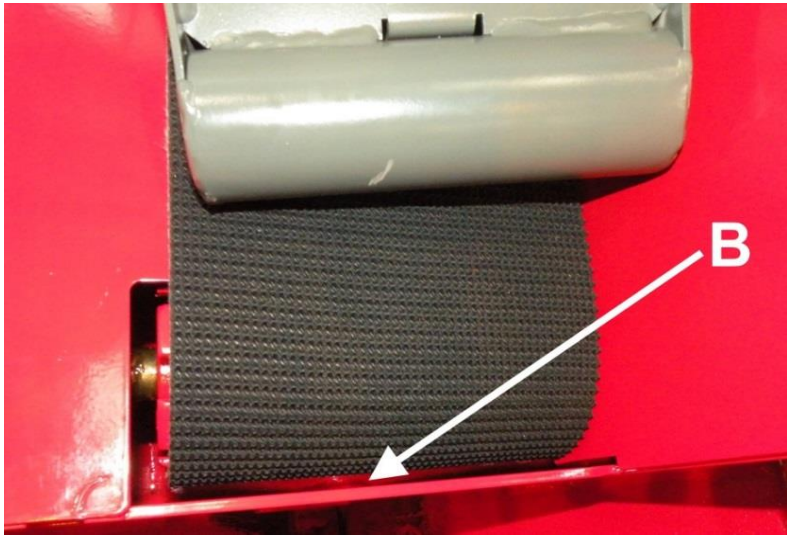

Figure 27

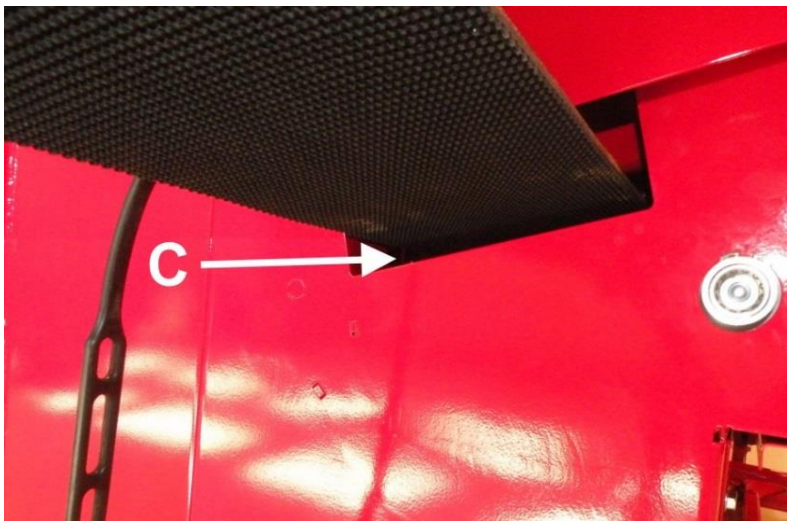

Figure 28

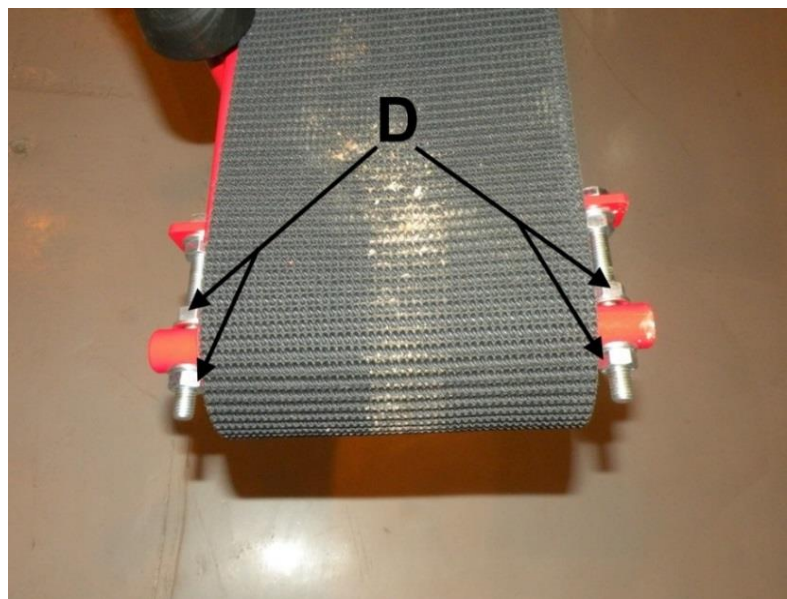

Figure 29

Replacing and tensioning the out-feed conveyor belt

The instructions for tensioning and aligning the out-feed conveyor are presented in Section 4.6.

Replace the out-feed conveyor belt as follows:

1. Pull out the pin locking the conveyor in place and lower the conveyor to the ground.
2. Shut the machine down and disconnect it from its power sources.
3. Move the belt joint to the start of the conveyor.
4. Fold the conveyor, but do not place the belt support in the transport position. This will allow the belt to hang loose.
5. Disconnect the joint by opening the bolts.
6. Remove the old belt.
7. First, insert the new belt under the folded conveyor (bottom opening) from the end of the conveyor with the plates facing downwards. Feed the belt in until you can pull it out from the other end of the conveyor. Pull out a length of approx. 60 cm.
8. Push the other end of the belt into the upper section of the folded conveyor (top opening) from the end of the conveyor. Feed it in until you can connect the joint.
9. Pull the excess belt to the start of the conveyor.
10. Open the conveyor to the operating position, and tighten and adjust the belt.

The belt is at the correct tension when its middle section is raised approx. 15 cm when the conveyor is in the operating position. An excessively tight belt may be damaged more easily, and it places unnecessary strain on the conveyor bearings.

Replacing the out-feed conveyor plates

The out-feed conveyor plates can be replaced by disconnecting the bolt joints (3 x M8) fastening the plates and replacing the plates with new ones. It is recommended that you move the belt into a position that puts the plate to be replaced above the conveyor. Shut the machine down and disconnect it from the power source for the duration of the procedure.

4.10. Lubrication

All of the firewood processor's lubrication points, which require Vaseline, have been labelled. Lubrication must be conducted at the designated maintenance intervals. There are 10 lubrication points, presented in figures 30-39 below. In order to access all grease nipples, remove the bolts circled in Figure 35 (or loosen them enough to slide the plate out) and remove the cover plate.

1. Cylinder nipples of the saw drive end (2 pcs) in Figure 31 and Figure 32 (every 50 hours)
2. Control shaft bearing nipples (2 pcs) in Figure 33 and Figure 34 (every 200 hours)
3. Grease nipple for the in-feed conveyor drive roller Figure 35 (every 200 hours)
4. Guard nipples (2 pcs) in Figure 36 and Figure 37 (every 50 hours)
5. Grease nipple for the out-feed conveyor's turning device in Figure 38 (every 50 hours)
6. Grease nipple for the log measuring device in Figure 39 (every 50 hours)
7. Motion booster sleeve J and bar in Figure 19 (every 200 hours)

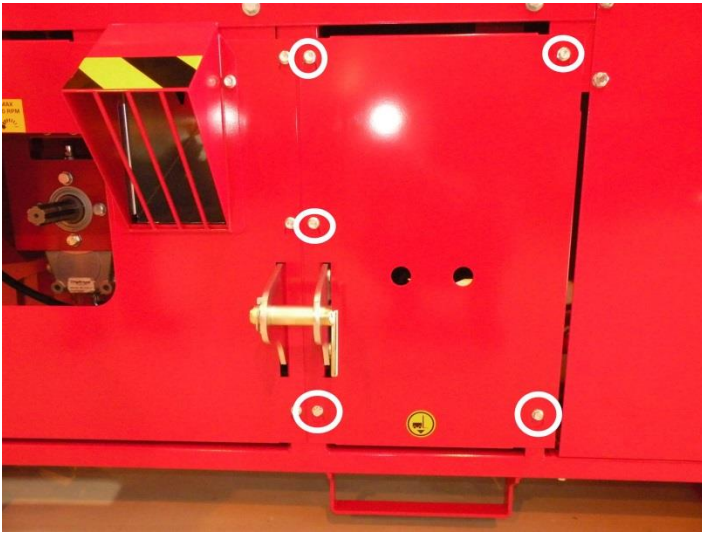

Figure 30

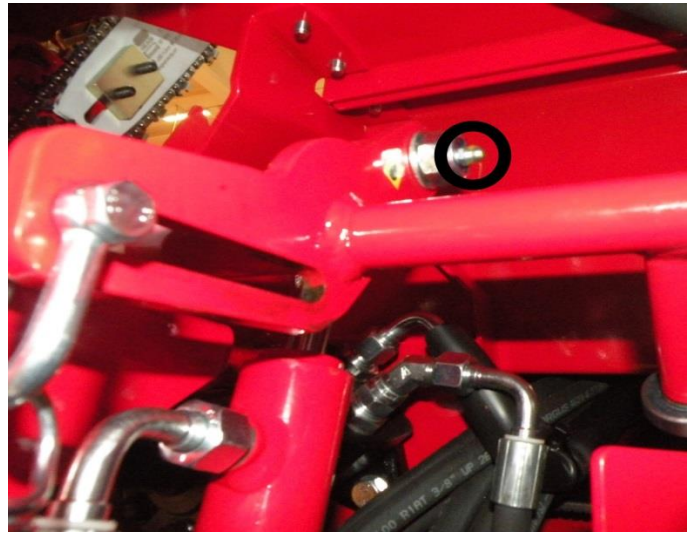

Figure 31



Figure 32

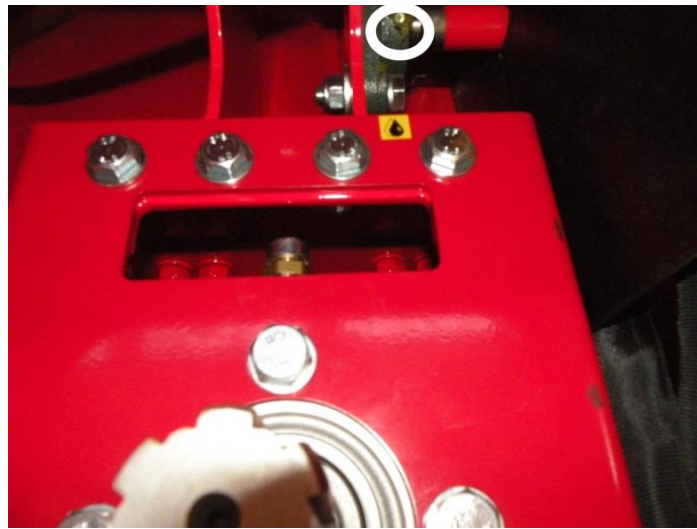

Figure 33

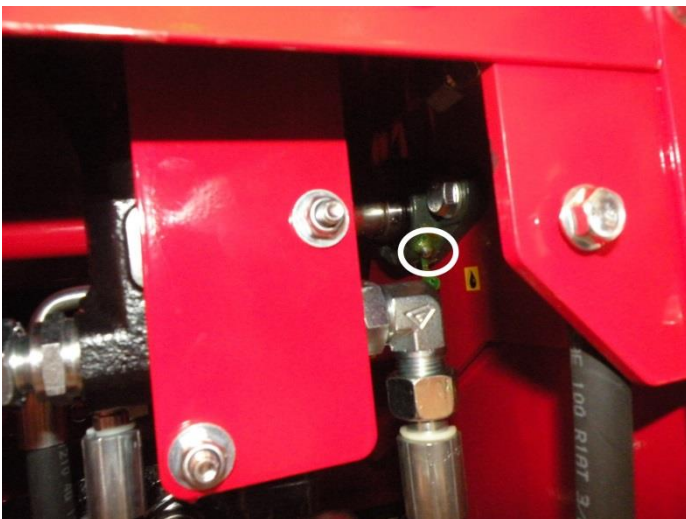

Figure 34



Figure 35



Figure 36



Figure 37



Figure 38

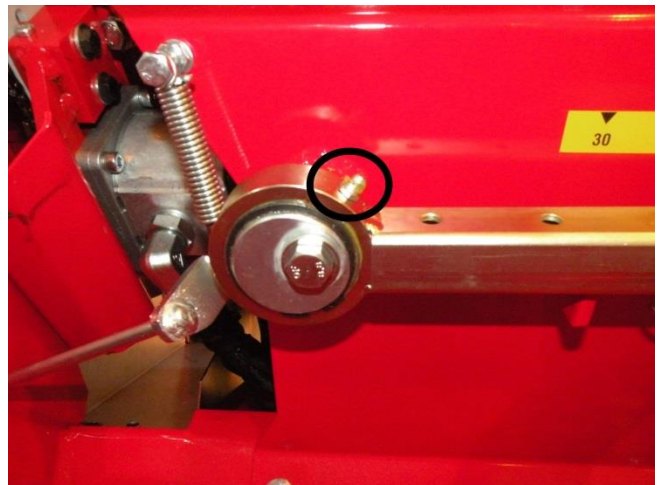

Figure 39

4.11. Saw chain lubrication

The saw chain is automatically lubricated whenever the saw bar is pressed down. The oil is dispensed from canister B onto the saw chain by means of pressure applied with an oil pump. A single pump stroke is carried out every time the saw bar is pressed downwards.

The amount of saw chain oil can be adjusted with adjustment screw F (Figure 41). When the screw is tightened, less oil is fed to the saw chain, and vice versa. If the pump needs to be bled, detach adjustment screw F entirely from the pump and press the pump piston repeatedly with a hex key, for example.

Inspection opening E can be used to monitor the oil level. Oil should be added when there is approx. 5 cm of oil left in the canister (Figure 42). Detach the protective cover of the canister by removing locking screw D and lifting the protective cover using opening C.

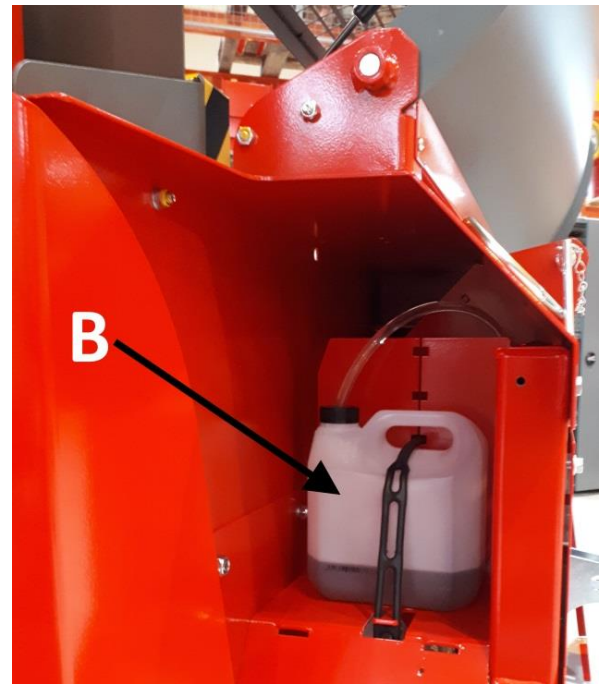

Figure 40

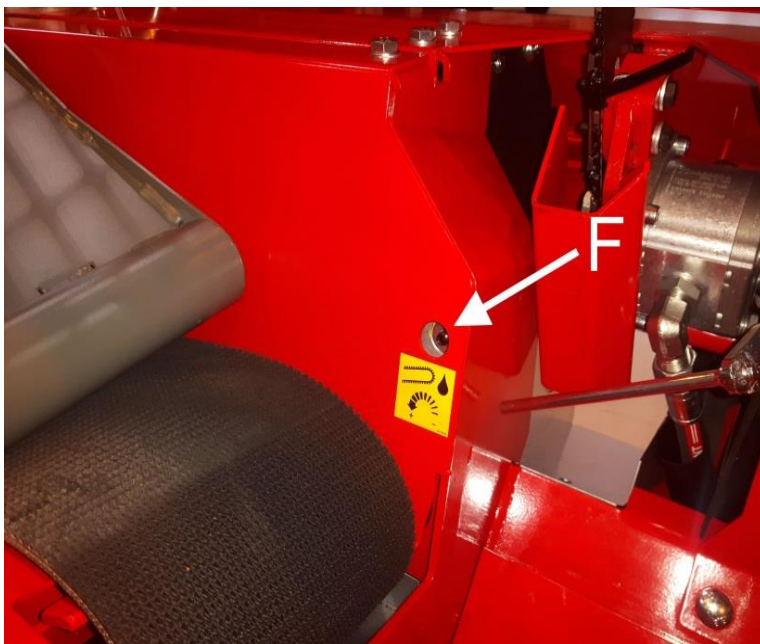

Figure 41

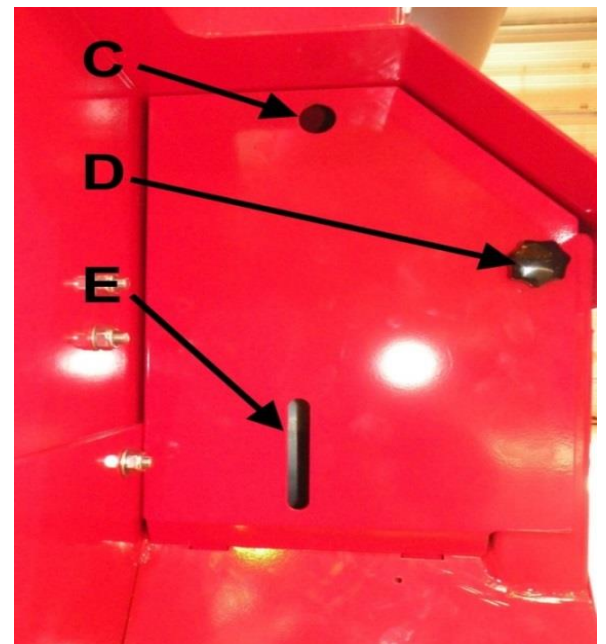

Figure 42

4.12. Solenoid and pressure regulating valves

The pressure regulating valves are adjusted to the correct settings at the factory. The firewood processor's guarantee is void if the factory settings are changed. If you need to change the settings for any reason, first contact the manufacturer or retailer and follow their instructions carefully. Changing the cartridge settings incorrectly may damage the machine or render it hazardous to operate. If the relief valve settings need to be changed, do it as follows: loosen the locking nut and tighten or loosen the hex socket screw as needed (when the screw is tightened, the pressure increases and vice versa). Finally, tighten the locking nut. The locations of the relief valves are indicated in the following figures.

1. Relief valve of the saw motor (200 bars) Figure 43
2. Relief valve of the splitting valve (240 bars) Figure 44
3. Relief valve of the acceleration valve (160 bars) Figure 45
4. Relief valve of the out-feed conveyor (200 bars) Figure 46
5. Relief valve of the safety valve (250 bars) Figure 47
6. Relief valve for the saw lowering motion (approx. 10 bar) Figure 48.
If necessary, adjust the valve's hex socket screw clockwise (lowering speed too low) or anticlockwise (lowering speed too high).

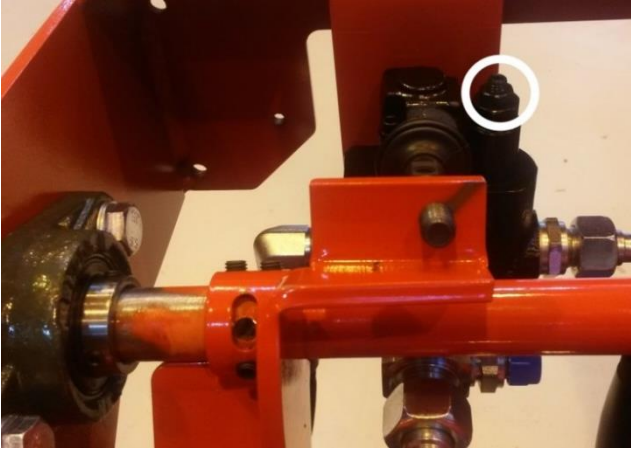

Figure 43

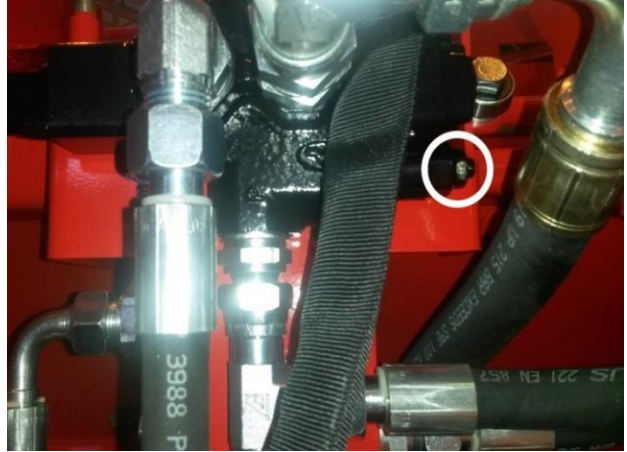

Figure 44



Figure 45

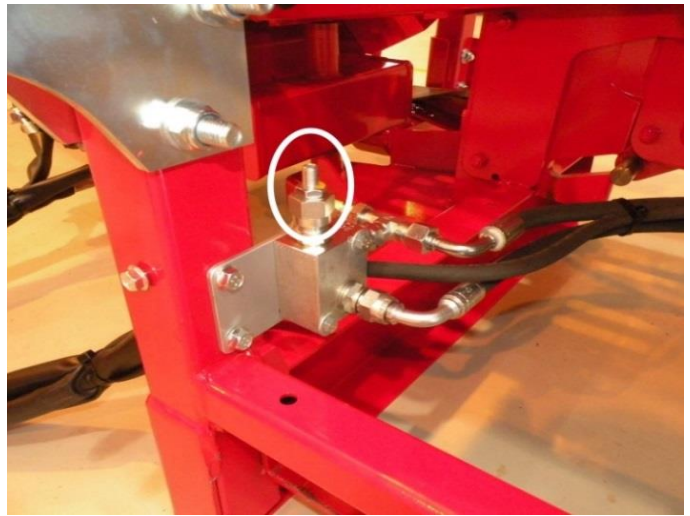

Figure 46



Figure 47



Figure 48

4.13. Washing and cleaning

Any loose dirt and sawdust can be removed from the machine with pressurised air, for example. The machine can also be washed with a high-pressure washer as long as the water jet is not aimed directly at the bearings or electrical equipment.

Always ensure that the machine and the working area are sufficiently clean during operation. The machine must always be cleaned after use. Clean the machine at suitable intervals and always before storing the machine for a prolonged time. After washing, the machine must be lubricated according to the instructions in Section 4.10.

4.14. Storage

The firewood processor must be stored on a level and solid foundation. Although the machine is intended for outdoor use, it should be covered and stored in a sheltered location or indoors. Before prolonged storage, the machine must first be cleaned, then washed according to Section 4.13 and lubricated according to Section 4.10.

4.15. Maintenance table

Item	Task	Daily	Interval		Substance/accessory item
			100 h	500 h	
Multiplier gear oils (TR and Combi models only)	Check 1st change Subsequent	X	X	X	SAE 80/90 approx. 0.5 l See section 4.8
Hydraulic oil Normal conditions	Check 1st change Subsequent	X	X	X	Quantity approx. 70 l, ISO VG 32, for example. In warm conditions and for the TR model, use ISO VG 46, for example
Oil filter	Always when changing oil				HEK02-20.201-AS-RP025-VM-B17-B Spare part no: 97348
All levers	Lubrication		X		Lubrication oil
Saw chain	Sharpen/ replace as necessary				0.325" 67vl 1.5 mm Recommendation: Oregon Spare part: 95416
Saw bar	Maintain/ replace as necessary				16" 1.5 mm Recommendation: Oregon Spare part: 95147
Machine	Clean Wash	X			
Electric motor	Cleaning	X			
Electrical equipment	Cleaning	X			
Winch and strap	Check	X			

5. Failures and remedial measures

5.1. Cause-effect table for failures and their removal

Failure	Cause	Remedial measure
The splitting force is insufficient to split the log.	<ol style="list-style-type: none"> 1. The log is in an incorrect position or the splitting blade is at the wrong height. 2. The previous log has jammed on the splitting blade. 3. The machine has overheated or the oil quality is poor. 4. Other fault 	<ol style="list-style-type: none"> 1. Open the cage and correct the log position or adjust the splitting blade. 2. Remove the jammed log. 3. Determine the cause of the overheating. Change the hydraulic oil and replace the return filter. 4. Contact the retailer.
The in-feed conveyor belt does not move.	<ol style="list-style-type: none"> 1. The belt is too loose. 	<ol style="list-style-type: none"> 1. Tighten the belt in accordance with the instructions in Section 4.9 "Replacing and tightening the belt of the in-feed conveyor".
The out-feed conveyor does not move.	<ol style="list-style-type: none"> 1. The belt is too loose. 2. The out-feed conveyor's relief valve is leaking. 	<ol style="list-style-type: none"> 1. Tighten the belt in accordance with the instructions in Section 4.9 "Replacing and tightening the belt of the out-feed conveyor". 2. Clean the relief valve (Figure 46) or replace it as necessary.
The cutting motion does not fully cut the log.	<ol style="list-style-type: none"> 1. The saw chain drags to one side or the bar is crooked. 2. The mechanism is clogged with sawdust. 3. The path of the saw bar is incorrectly adjusted. 	<ol style="list-style-type: none"> 1. Maintain the saw chain/bar. 2. Clean the machine. 3. Contact the retailer.
The saw chain does not properly sink into the wood.	<ol style="list-style-type: none"> 1. The saw chain is dull or drags to the side (due to uneven sharpness). 2. The saw bar is crooked. 3. The lowering speed of the saw bar is too high. 	<ol style="list-style-type: none"> 1. Sharpen or replace the saw chain. 2. File the bar to make it straight and/or turn the bar. 3. Decrease the lowering speed by turning the hex socket screw in Figure 48 as instructed
The machine starts but none of the functions work. The machine makes an abnormal noise.	<ol style="list-style-type: none"> 1. The electric motor runs in the wrong direction. 	<ol style="list-style-type: none"> 1. See Section 2.4
The electric motor does not start.	<ol style="list-style-type: none"> 1. The machine makes a loud noise but does not start. 2. The input cable is faulty. 3. The thermal relay has tripped. 	<ol style="list-style-type: none"> 1. The gear fuse has blown. Replace it. 2. Replace the cable. 3. Reset the thermal relay with the stop button at the rear of the machine (starter), and determine the cause of the overload.

The motor tends to stop, and the thermal relay is easily tripped.	<ol style="list-style-type: none"> 1. Check the supply voltage and the sufficient thickness of the supply cable. 2. The thermal relay is broken or incorrectly adjusted. 	Contact the retailer.
The splitting action does not start or stay on after the sawing motion.	<ol style="list-style-type: none"> 1. The saw mechanism is worn and does not activate the position lock (Figure 18, item E) 2. Fault in the splitting valve 	<ol style="list-style-type: none"> 1. Adjust bolt E to extend the length about 1 mm. 2. Contact the retailer.
The splitting beam makes extra splitting motions.	<ol style="list-style-type: none"> 1. Excessive speed at the tractor power take-off. 2. Other fault 	<ol style="list-style-type: none"> 1. Adjust the speed to the correct level. 2. Contact the retailer.
The splitting beam stops prematurely.	<ol style="list-style-type: none"> 1. The motion booster stops the slide in the incorrect position. 	<ol style="list-style-type: none"> 1. Grease the motion booster sleeve and loosen the spring as necessary.

5.2. Jamming of the cutting blade

If the cutting blade gets jammed in the log, stop sawing and try again on another section of the log. If the cut is misaligned because the bar drags to one side, the degree of sharpness of the saw chain must be checked. A chain that is not evenly sharp will always drag towards the blunter side, which will make cutting a thick log impossible. On the other hand, sawing with an evenly dull chain is inefficient, and the saw chain must be sharpened or replaced (see Section 0). A worn flange may also cause chain drag or jamming. In these cases, the flange must be serviced and/or turned or replaced with a new one.

5.3. Jamming of wood on the splitting blade

If a piece of wood gets jammed on the splitting blade in a situation where the splitting force is insufficient to push the piece past the blade despite several attempts to do so, do the following:

1. Restore the splitting cylinder to its initial position with reversing lever A (Figure 11).
2. Ensure that the log to be split does not exceed the maximum allowable dimensions.
3. Lift the splitting blade to the highest possible position with lever G (Figure 11) and activate the splitting.
4. If necessary, cut a sufficiently thick piece of wood (approx. 10 cm), place it into the splitting groove behind the jammed piece, and activate the splitting process. The new piece will then push the bottom part of the jammed piece past the blade.
5. Lower the blade by approx. 5 cm and repeat step 3. Repeat step 4 until the jammed log has passed the blade, piece by piece.

7. Guarantee terms

We offer a guarantee on our machines, with the following conditions:

1. This guarantee covers defects caused by manufacturing or material failures, except for defects in components that are classified as parts that will sustain wear and tear.
2. The guarantee is valid for the original buyer for one (1) year, starting from the day of purchase, but for no more than 1,000 operating hours.
3. The guarantee becomes void if
 - a. the instruction manual is not observed when using the machine
 - b. the machine is used for a purpose other than which is defined by the manufacturer
 - c. modifications are made to the operation of the machine
 - d. parts that are not original spare parts are used in the machine
 - e. the maintenance procedures defined in the instructions are neglected.
4. A guarantee demand has to be issued in writing **immediately** upon discovery of a defect to the seller or the manufacturer. Repair under guarantee requires that the customer can reliably prove that the guarantee is valid.
5. The guarantee does not include standard adjustments, user guidance, care, maintenance or cleaning procedures.
6. Repair under guarantee requires that no attempts have been made to fix the machine or a part of it before a written notification of the defect has been issued to the seller, manufacturer or importer.
7. Only a serviceman authorised by the **manufacturer or the importer** is allowed to carry out a repair under guarantee. Washing, cleaning, or changing oils and fuels done while carrying out the said repair are not covered by the guarantee.
8. The repair work costs are compensated for according to the standards defined by the manufacturer.
9. The manufacturer of the machine is not liable to compensate for any travelling costs that may result from the repair work.
10. A spare part will be delivered free of charge when using the usual means intended for such parts, in accordance with the normal schedule.
11. The receiver is liable for costs occurring from special deliveries, such as express mail.

8. EC Declaration of Conformity for the machine

(Machinery Directive 2006/42/EC, Appendix II A)

Manufacturer: TP Silva Oy

Address: Valimotie 1, FI-85800 Haapajärvi, Finland

Name and address of the person who is authorised to compile the technical file:

Name: Timo Jussila

Address: Valimotie 1, FI-85800 Haapajärvi, Finland

The aforementioned person assures that

Hakki Pilke Falcon firewood processor

Serial number:

- is compliant with the applicable regulations of the Machinery Directive (2006/42/EC).

Location and date: Haapajärvi, 01 October 2020

Signature:



*Anssi Westerlund
Managing Director*