

# Hakki Pilke 25

# Hawk

## FIREWOOD PROCESSOR

- Instructions for assembly, operation and maintenance
- EU Declaration of Conformity
- Safety instructions
- Guarantee terms



**The operator must read and understand these instructions before operating the firewood processor!**

**Keep this manual with the machine for later use**

*MAASELÄN KONE OY*

Valimotie 1, FI-85800 Haapajärvi, Finland  
Tel. +358 (0) 8 772 7300, Fax +358 (0) 8 772 7320

[info@maaselankone.fi](mailto:info@maaselankone.fi)

[www.maaselankone.fi](http://www.maaselankone.fi)

## Table of contents

<b>1. General information</b> .....	<b>4</b>
1.1. Introduction.....	4
1.2. Purpose of use.....	4
1.3. Machine models and basic information.....	4
1.4. Operating conditions.....	5
1.5. Safety instructions.....	5
1.6. Noise and vibration.....	5
1.7. Warning symbols.....	6
<b>2. Setting up the machine for operation and transport</b> .....	<b>8</b>
2.1. Receipt inspection.....	8
2.2. Main components of the machine.....	8
2.3. Arranging the machine for operation and transport.....	9
2.4. Transport of the machine.....	11
<b>3. Operating the machine</b> .....	<b>14</b>
3.1. Controls and functions of the machine.....	14
3.2. Before using the machine.....	15
3.3. Performing a test run on the machine.....	16
3.4. Activating and deactivating the machine.....	17
3.5. Using the output conveyor.....	20
3.6. Feeding and sawing wood.....	21
3.7. After use.....	22
<b>4. Maintenance and adjustment of the machine</b> .....	<b>23</b>
4.1. Disconnecting the machine from its power source.....	23
4.2. Adjusting the log length.....	23
4.3. Adjusting and detaching the splitting knife.....	24
4.4. Adjusting the length of the splitting motion.....	25
4.5. Cutting blade and drive end.....	26
4.6. Changing the oil.....	28
4.7. Conveyor maintenance.....	29
4.8. Lubrication.....	30
4.9. Pressure adjustment valves.....	31
4.10. Washing and cleaning.....	32
4.11. Storage.....	32
4.12. Maintenance table.....	32

<b>5. Failures and remedial measures .....</b>	<b>32</b>
5.1. Cause-effect table for failures and their removal .....	32
5.2. Jamming of the cutting blade and inefficient sawing .....	33
5.3. Jamming of the wood on the splitting knife.....	33
<b>6. Hydraulics diagram.....</b>	<b>34</b>
7. Guarantee terms .....	35

# 1. General information

## 1.1. Introduction

The purpose of this manual is to ensure that the machine is used in the manner intended by the manufacturer, taking safety into consideration. Everyone operating the machine or working in close proximity to it must study this manual carefully.

Operators of the machine are expected to have basic skills in tractor handling, such as utilising the cardan shaft drive and the tractor's lifting equipment. When a tractor is used as the power source, the operator must, in addition to this manual, study the tractor's manual and observe the instructions it provides. Before commencing work, operators must also familiarise themselves with the machine's control and safety equipment, and ensure their proper operation.

Additional information on Maaselän Kone Oy's products is available on our website at [www.maaselankone.fi](http://www.maaselankone.fi).

**Keep this manual in the immediate vicinity of the machine!**

## 1.2. Purpose of use

The Hakki Pilke 25 Hawk firewood processor is designed for preparing firewood from pruned wood or logs. The firewood processor must not be used to process any treated wood, such as is found in construction waste. Sand, nails or other impurities in the wood may damage the machine.

The maximum diameter of the logs to be split is 25 cm. This limit must not be exceeded. When estimating the diameter of the log you are about to cut, note that the shape of the log and other factors, such as branches and burrs, make the actual diameter larger, and may prevent the log from being fed into the machine. The splitting groove is designed for logs up to 40 cm in length. Never split logs that exceed the maximum length.

## 1.3. Machine models and basic information

Model	Hakki Pilke Hawk 25			
Driving power	Combustion engine	Tractor	Electricity	Tractor hydraulics
Weight	460 kg	400 kg	460 kg	
Height/width/length in the transport position	262/138/405 cm	248/104/223 cm	262/138/405 cm	
Input/output conveyor	184/200 cm	Same	Same	Same
Saw bar/chain	13" 56 loops/1.3 mm	Same	Same	Same
Max. diameter of log (cm)	25	25	25	25
Max. length of log to be split (cm)	40	40	40	40

The machine's serial number, manufacturing date, weight, operating voltage (electrically-operated machines) and model are indicated on the grey type plate located by the lifting point to the right of the operator (see Figure 8).

## 1.4. Operating conditions

- The temperature range within which the machine can be operated is -20 to +30°C. In the winter, the operator must ensure that there is no risk of slipping in the working area.
- The working area must be level and clear of unnecessary items. No unauthorised persons must enter the working area. The working area must also be sufficiently illuminated. These requirements must be met for the entire duration of the work.
- The machine may not be used indoors.

## 1.5. Safety instructions

- Only one person may operate the machine. The danger zone around the machine is 10 metres.
- Persons under 18 years of age may not operate the machine.
- The machine may not be used if it causes danger to others or there are unauthorised persons in the danger zone.
- The machine may not be operated while under the influence of alcohol or other drugs, or when tired.
- The machine may not be operated unless the operator has familiarised themselves with this instruction manual.
- The machine may only be used for making firewood.
- The machine must be placed in the transport position whenever it is moved.
- The operator is not permitted to modify the structure or operation of the machine, or to remove protective equipment.
- Operators must wear ear protection, sufficiently tight-fitting work clothing, work gloves, protective goggles and safety footwear.
- Before starting up the firewood processor, the operator must ensure that the machine and its guards are intact. The machine may not be used if the machine itself or the guards are not intact.
- Before starting up the firewood processor, the operator must ensure that all the control and safety devices are functional. The machine may not be operated if the control and safety devices are not functioning as intended.
- Before beginning work, the operator must ensure that the machine works normally (see Section 4.1 Test run).
- When cleaning or maintaining the machine, it must be deactivated and disconnected from its power source.

**Note! Do not leave a running machine unsupervised!**

## 1.6. Noise and vibration

The A-weighted sound pressure level at the working location is 87.0 dB (A), and the sound power level is 98.0 dB (A). The vibration values do not exceed 2.5 m/s<sup>2</sup>.

## 1.7. Warning symbols

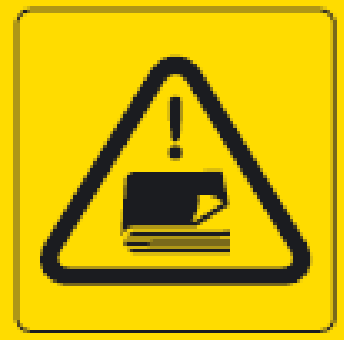

*Read the machine's manual before operating the machine.*



*Wear eye and ear protection.*



*Wear safety footwear and work gloves.*

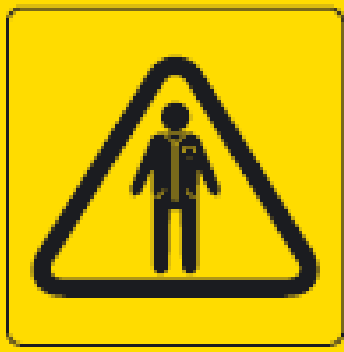

*Do not wear any loose items of clothing.*



*Always grab the piece of wood or log from the side.*



*Lifting point for forklift.*

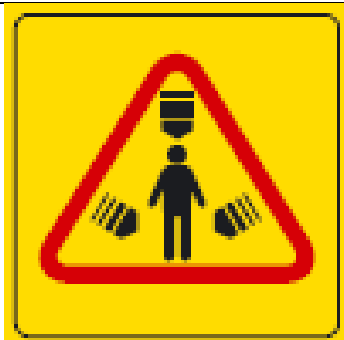

*Beware of moving parts.*



*Beware of the cardan shaft.*



*Beware of the chain.*



*Beware of the blade.*



*Only one person may operate the machine.*

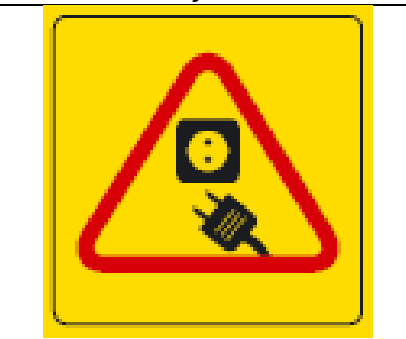

*Disconnect the power supply before maintenance procedures.*

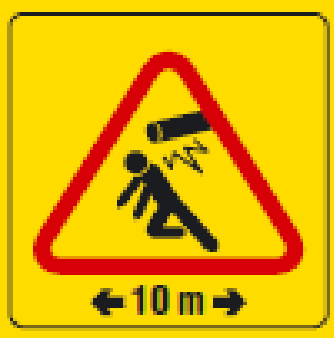

The danger zone around the machine is 10 metres.



Risk of crushing



The maximum permitted angle of the conveyor is 40°.  
Do not walk under the conveyor.



The maximum speed for the cardan shaft is 410 rpm.

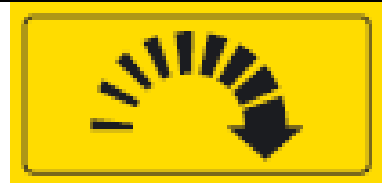

The rotation direction is in the direction of the arrow.



Hydraulic oil

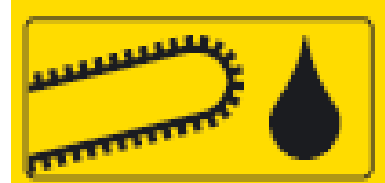

Saw chain oil



Danger zone



Lubrication point

## 2. Setting up the machine for operation and transport

### 2.1. Receipt inspection

Dispose of the machine's packaging materials in the appropriate manner.

Check that the machine has not sustained any damage during transit, and ensure that all necessary parts are included in the package. In the event of any defects or damage, contact the retailer immediately.

### 2.2. Main components of the machine

The Hakki Pilke Hawk 25 includes the following main components:

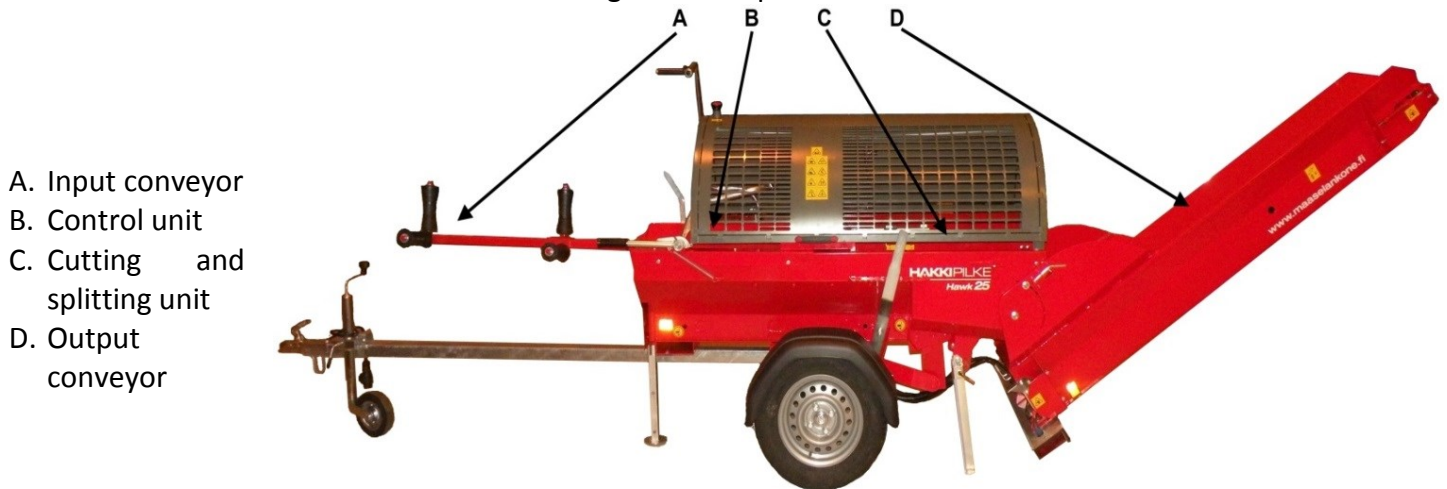

*Figure 1. Main components of the machine.*

### 2.3. Arranging the machine for operation and transport

Before arranging the machine for transport, ensure that the machine is used in the operating conditions detailed in Section 1.4 and in accordance with the safety instructions in Section 1.5. Disconnect the machine from the towing vehicle's hook as instructed in Section 2.5. Then arrange the machine for operation as follows:

1. Pull the locking latch A, which releases the lock, and lower the support leg B to the working position, as shown in Figure 2.
2. Tighten the front wheel leg D to the lower position using the tensioner E.
3. Adjust the machine to a horizontal position using the crank C (in Figure 3) in accordance with the instructions in Figure 4.



Figure 2.

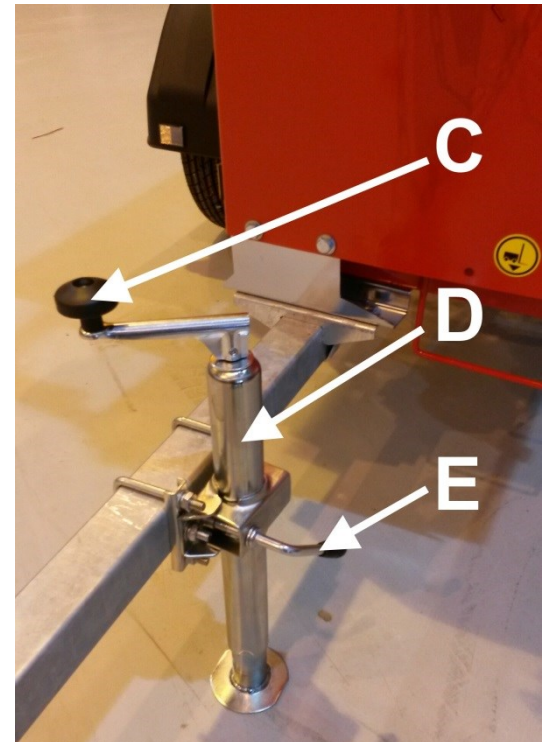

Figure 3.

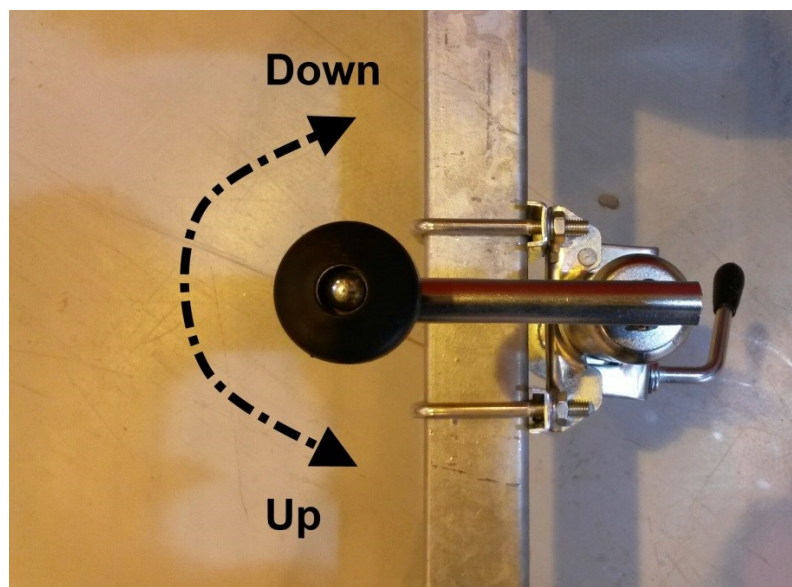

Figure 4.

To place the machine in the transport position, reverse the order of the steps listed above.

**Note!** The machine must be inspected and cleaned according to sections 3.7 and 4.10 before setting it up for transport.

## Placing the output conveyor in the operating or transport position

Place the output conveyor in the operating position as follows:

1. Ensure that there is sufficient room for lowering the output conveyor, and there are no other persons or animals in the machine's danger zone.
2. Turn off the machine and disconnect it from the power source.
3. Press the locking latch handle A (Figure 5) down, which releases the latch from the bar.
4. Slowly turn the conveyor (the gas springs slow down the motion) into the working position to rest on the stopper bolt D (Figure 5), using the handles C (Figure 6).

**Place the output conveyor in the transport position by lifting the conveyor to the upper position using the handles C (Figure 6). Note! Ensure that the conveyor is locked in the transport position using the locking hatch A and bar B, as shown in Figure 5.**

**Note! Do not stand on the output conveyor!**

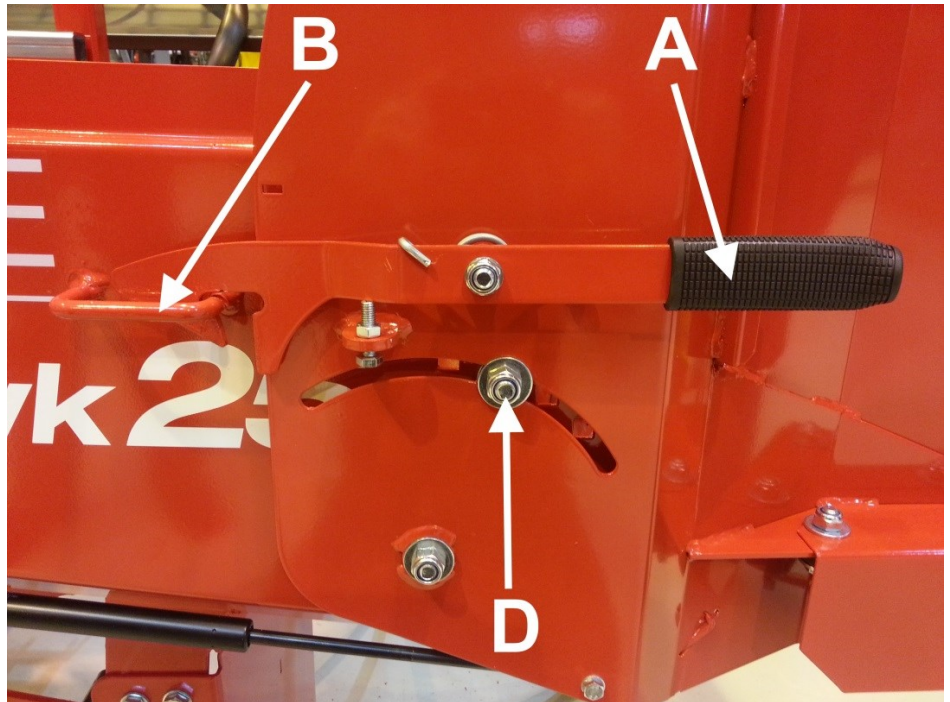

Figure 5.



Figure 6.

## Lifting and moving the machine

A firewood processor driven by a combustion engine or electric motor includes transport wheels, which means that the machine should be moved using the wheels whenever possible.

When moving the machine with forklift spikes, always make sure that the moving and lifting capacity of your tractor or forklift is sufficient for the weight of the machine. When using forklift spikes, only lift the device by the lifting points A indicated in Figure 7.

A tractor-operated machine must be lifted from the points B shown in Figure 8.

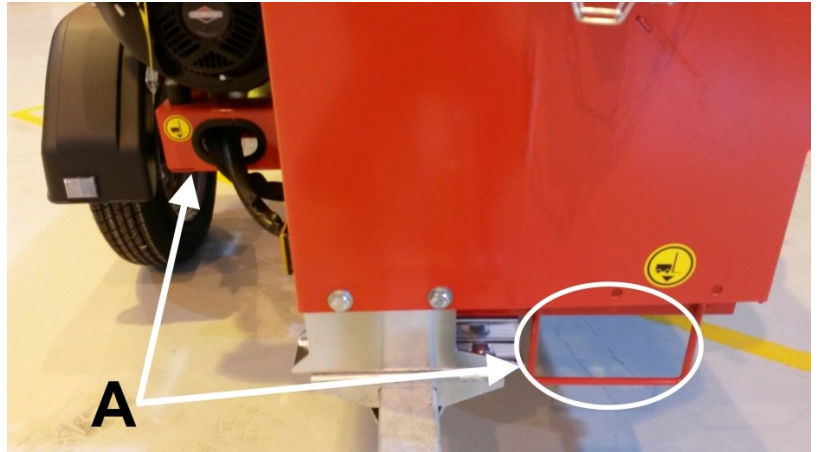

Figure 7. Lifting points for a towable model.

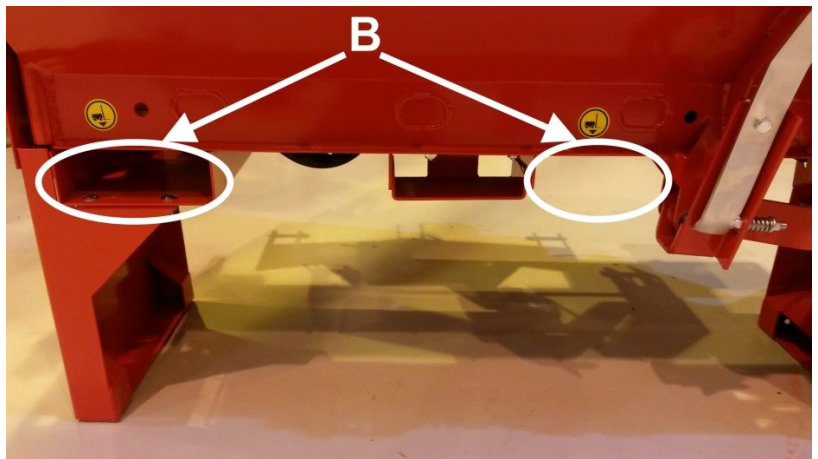

Figure 8. Lifting points for a tractor-operated model.

**Note! Incorrect lifting may cause a hazardous situation or damage the machine.**

### 2.4. Transport of the machine

- Before transporting the firewood processor, always ensure that the machine and the conveyor have been arranged for transport in accordance with Section 2.3.
- Before towing the machine with a vehicle, check:
  - the fastening of the towing bar of the transport chassis to the vehicle's towing hook
  - the fastening of the electrical connector of the transport chassis to the vehicle
  - the correct functioning of the signal lights of the transport chassis
  - that the conveyor and its supports are locked in the transport position
  - the air pressure and tread of the tyres; the correct tyre pressure is 2.0 bar
  - the condition of the towing bar and its fastening parts.

**Note! Observe the relevant national legislation concerning transport!**

## Attaching the transport chassis to the vehicle's towing hook

1. Move the vehicle to the towing bar of the transport chassis.
2. Align the ball coupling of the transport chassis with the vehicle's towing hook.
3. Lift the front wheel to the top position (Section 2.3), which lowers the towing bar and locks the ball coupling to the towing bar, as shown in Figure 9 (indicator A is in the green area, as illustrated in Figure 9).



Figure 9.

4. Ensure the hold of the attachment by moving the towing bar up and down a few times.
5. Connect the electrical connector B to the vehicle's socket C, as shown in Figure 10.
6. Check the functioning of the lights. The brake lights of the transport chassis must function at the same time as the brake lights of the towing vehicle. The indicator lights of the transport chassis must function at the same time and indicate the same directions as the signals of the towing vehicle.

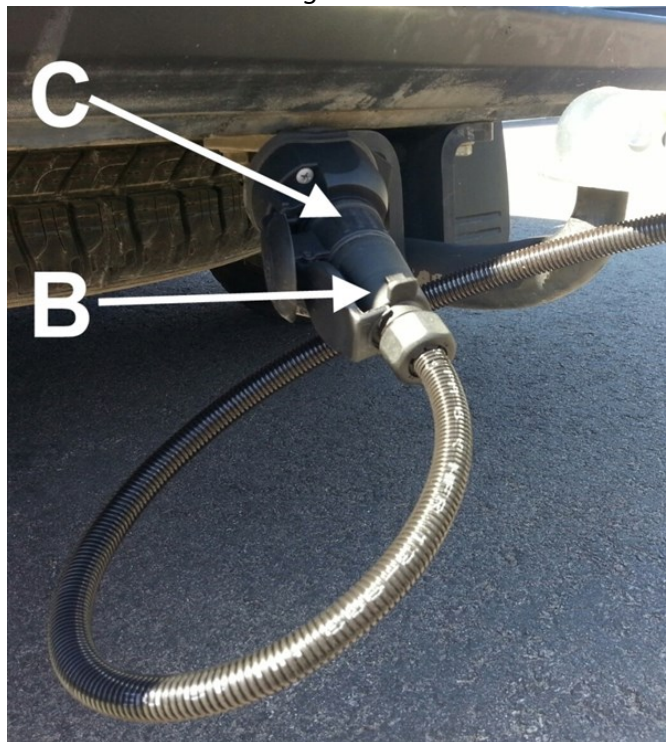

Figure 10.

## Detaching the transport chassis from the vehicle's towing hook

1. Disconnect the electrical connector B (Figure 10). Grip and pull the connector's plastic section instead of the cable.
2. Lower the front wheel B (Figure 11), and tighten the wheel to the lowered position (Section 2.3).
3. Lift the ball coupling handle C (Figure 11), so that it disconnects from the vehicle's towing hook when indicator A (Figure 11) is on the right side, as shown in Figure 11.

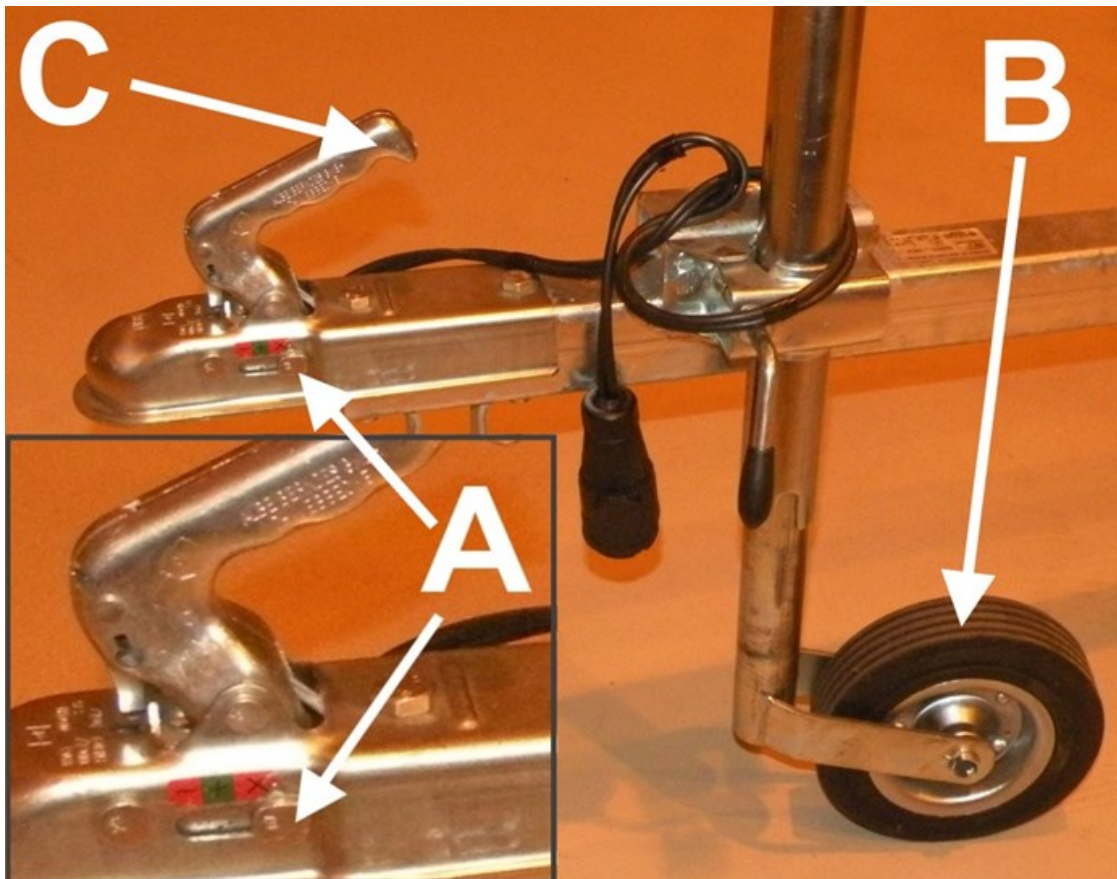

Figure 11.

### 3. Operating the machine

#### 3.1. Controls and functions of the machine

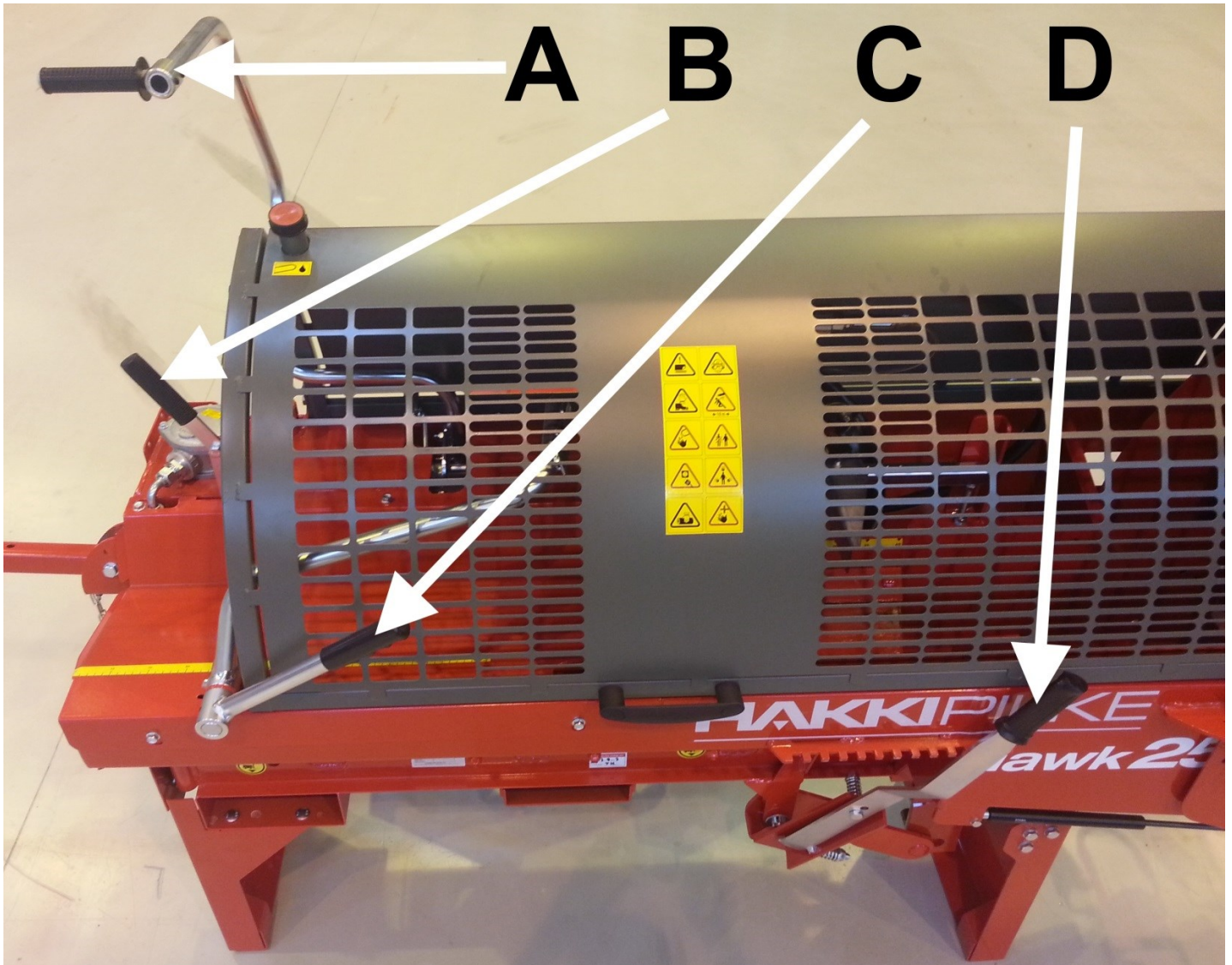

Figure 12. The machine's controls.

Names and functions of the controls in Figure 12:

- A. Control lever of the saw and splitter. This lever is used to control the cutting and splitting functions.
- B. Splitting cylinder activation and reversing lever. The splitting can be cancelled manually in the middle of the splitting motion by moving the lever to the left. The splitting can be activated by pushing the lever to the right.
- C. Wood gripper. The gripper presses the wood against the input table, which ensures safer and more stable cutting.
- D. Height adjustment lever for the splitting knife. The lever is used to move the splitting knife up/down by moving the lever to the right/left.

### 3.2. Before using the machine

A test run must be performed and all of the machine's functions must be tested before the actual operation of the machine (Section 3.3). Both the test run and the testing can only be performed by a person who has studied the machine's manual.

All of the components of the firewood processor must be checked before using the machine. If any faults or wear and tear that may affect the safe use of the firewood processor are discovered, the machine must not be used until the faulty or worn component is replaced and safe use can be ensured.

Before using the machine, ensure that:

- the machine has not sustained any damage
- the machine's operating environment is in accordance with Section 1.4
- the machine is positioned on a solid foundation
- no unauthorised persons are within the machine's danger zone
- all guards and safety devices are in place and functional
- the machine's stopping devices are functional (see items 10, 12 and 14 of Section 3.3)
- the hydraulic hoses and pipes are undamaged (the pipes must be replaced if there is a tear in the hoses or pipes, if they leak, or if the surface layer of the hydraulic hose has worn all the way down to the supporting weave.)
- the machine does not leak oil
- the machine functions properly (Section 3.3).

**Note! Do not use the machine if the requirements listed above are not met!**

### 3.3. Performing a test run on the machine

1. Check that the guard for the firewood processor's cutting and splitting section is down.
2. Check that the input and output conveyors are in the operating position.
3. Ensure that the splitting groove is empty.
4. Make sure that you are familiar with the functions of the splitter's controls. If necessary, refer to Section 3.1.
5. Start the machine as instructed in Section 3.4.
6. Activate the splitting motion by lowering the saw bar fully to the lowered position using the machine lever A (Figure 12). Then, raise the lever back to the top position. The splitting motion must be normal (the bar pushing the log being split moves fully to the front position close to the splitting knife and returns to the starting position automatically).
7. Start the splitting motion using lever B (Figure 12), by turning the lever to the right. The splitting motion must be normal, as described in item 6.
8. Ensure that the saw chain is activated when the bar is lowered (lever A) by about 2 cm.
9. Ensure that the saw chain lubrication functions properly: perform a few sawing motions, deactivate the machine and then check that the chain is sufficiently lubricated with oil (if necessary, see Section 4).
10. Ensure that the splitting cylinder returns to its initial position (even in the middle of the splitting motion) by pushing the lever B in Figure 12 to the left.
11. Ensure that the output conveyor runs at the normal rate (approx. 0.5 m/s) and the belt is positioned centrally on the conveyor. If necessary, adjust the conveyor in accordance with Section 3.5.
12. Ensure that the splitting motion stops when the guard is opened.
13. Ensure that the guard does not open when the cutting blade is spinning or the splitting bar is moving.
14. Ensure that the splitting motion or saw blade cannot be activated with the guard open.

If a fault occurs during the test run, stop using the machine immediately. The cause of the fault must be determined and remedied before continuing operation. Deactivate the machine and disconnect it from the power source for the duration of both the diagnostics and repairs.

### 3.4. Activating and deactivating the machine

#### Combustion engine model

The Hakki Pilke 25 firewood processor is powered by a B&S 420 petrol engine, which has 13 hp. Start the machine as follows:

1. Lift the guard of the firewood processor using the handle F (Figure 13). This closes the hydraulic circuit of the splitting and cutting functions, which means that the machine will start better thanks to the lower load.

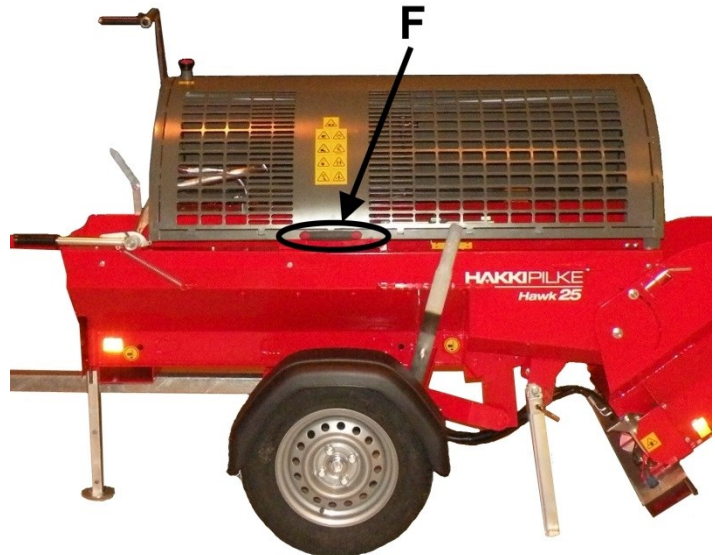

Figure 13.

2. Switch the engine's power on by turning the switch B to position 1 (Figure 14).
3. Open the petrol valve by turning the lever D to the right and, **IF NECESSARY**, engage the choke (when the machine is too **cold** to start without it) by turning the lever C to the left (Figure 14).
4. Turn the throttle lever A to the midway point (Figure 11).
5. Pull the handle E until the engine starts. If necessary, use the throttle lever A (Figure 14) to increase the engine's rpm.
6. Close the guard of the firewood processor using the handle F (Figure 13).

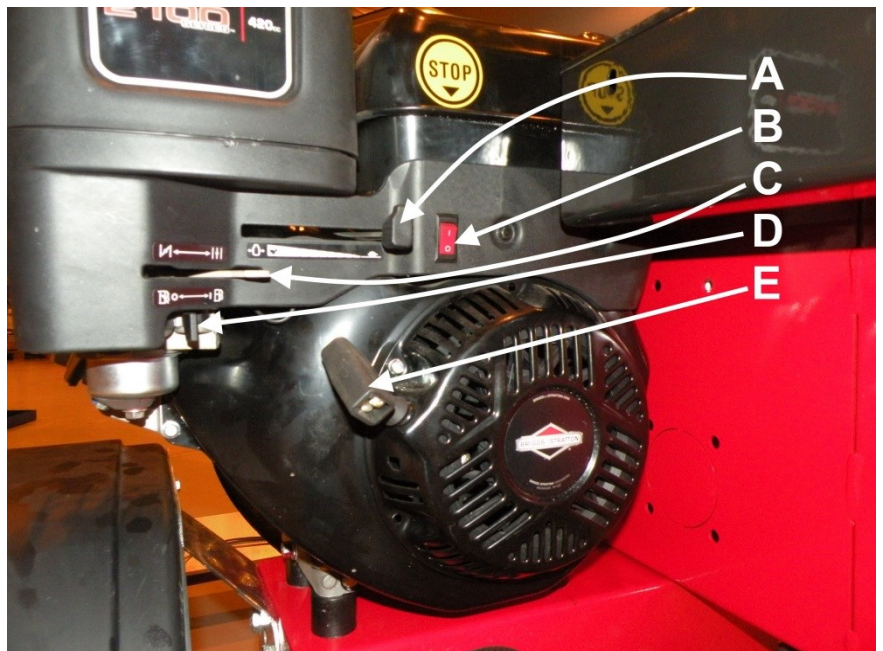

Figure 14.

Turn off the machine by turning the lever b (Figure 14) to the 0 position. **Note! Allow a hot engine to idle for a moment before turning it off.**

## Electrically-powered model

1. Ensure that there are no inappropriate objects in the splitting groove and output conveyor.
2. Connect the power cable (16 A connector) to the socket C in Figure 15.
3. Start the electric motor using the button A (Figure 16).

If the electric motor rotates in the wrong direction (i.e. the machine makes an abnormal noise and the hydraulic functions are inoperable), the current phase is incorrect. We recommend using an extension cord that allows you to switch the current phase, or an adapter.

**Note!** If the extension cord does not have a phase switch, the electrical work related to changing the phase must only be performed by an electrician.

Turn the machine off using the off button B (Figure 16).



Figure 15.

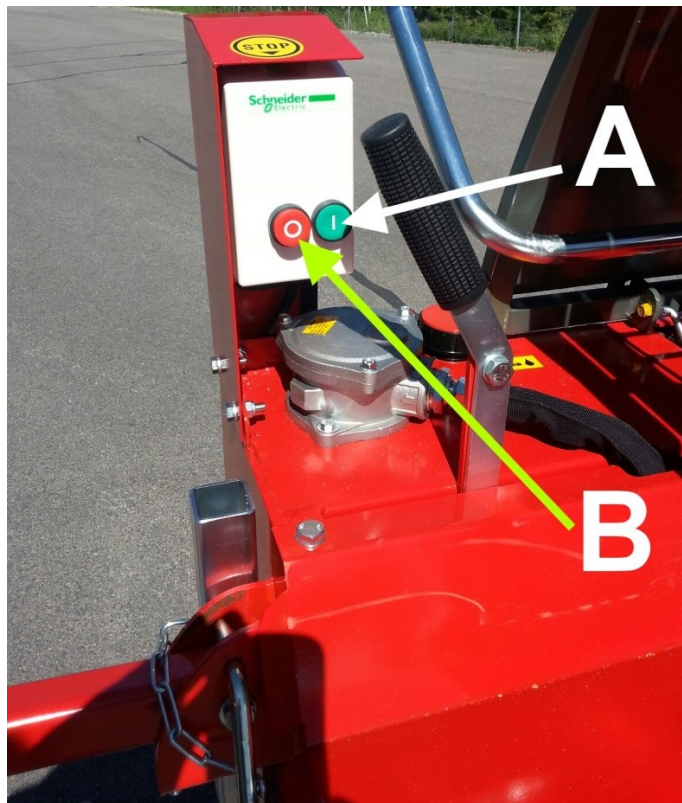

Figure 16.

## Tractor-powered model (PTO)

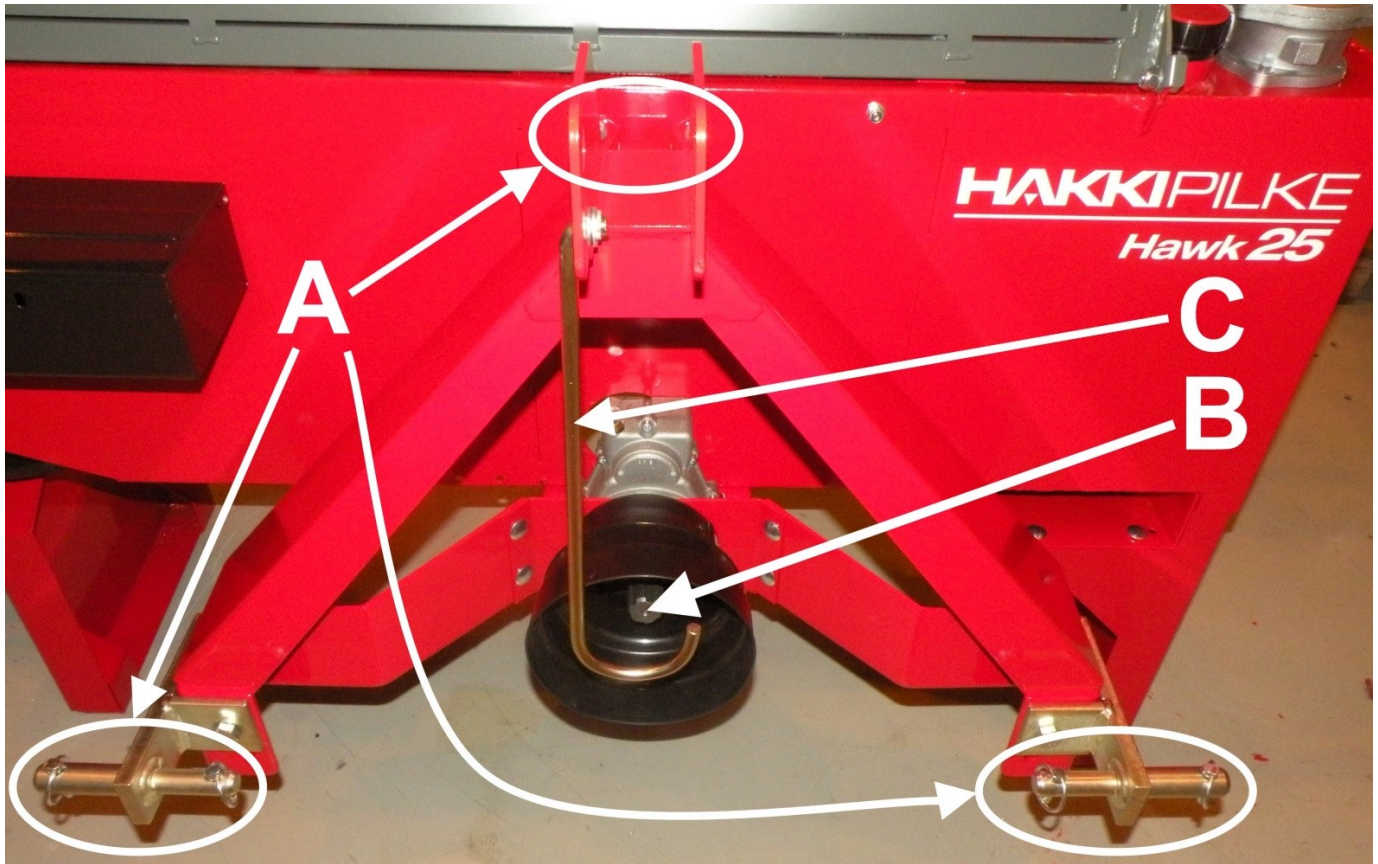

Figure 17.

1. Connect the tractor to the machine's three attachment points A, which are presented in Figure 17.
2. If necessary, turn the angle transmission bracket C (Figure 17) to the upper position out of the way of the cardan shaft, and connect one end of the cardan shaft to the tractor's PTO shaft and the other end to the multiplier gearbox shaft B (Figure 17).
3. Ensure that there are no inappropriate objects in the splitting groove and output conveyor.

Note! Connecting the cardan shaft is a task for only one person. The tractor cabin must be free of people in order to prevent accidental contact with the controls while the log splitter is being connected to the tractor. Check all the connecting devices of the tractor and the log splitter before connecting them. Never use faulty equipment.

4. Ensure that the connected shaft is locked onto the splined shaft of the multiplier gearbox. Hang the cardan shaft from the hook C when the machine is not in use and it is disconnected from the tractor. Finally, ensure that all the connections are safe and secure. Never use a damaged or unprotected cardan shaft.
5. Start the tractor and set the tractor's PTO shaft to rotate at a maximum of 410 rpm.
6. Once you have finished your work, turn off the machine as follows: switch the PTO shaft off, turn off the tractor, disconnect the cardan shaft from the splined shaft B and hang the cardan shaft from the hook C (Figure 17).

### 3.5. Using the output conveyor

In the Hakki Pilke Hawk 25 firewood processor, the output conveyor belt begins to spin immediately upon activation of the machine. The output conveyor is powered by the hydraulic motor, which activates immediately when the machine is started.

#### Adjusting the angle of the output conveyor

The angle of the output conveyor can be set to four different positions by changing the position of the stopper bolt D (Figure 6) in the holes E **when the conveyor is in the transport position (see Section 2.3 “Placing the output conveyor in the operating or transport position”)**.

**Note! The maximum operating angle for the output conveyor is 40°!** The maximum angle is indicated in the label in Figure 19 and the instructions attached to the output conveyor.

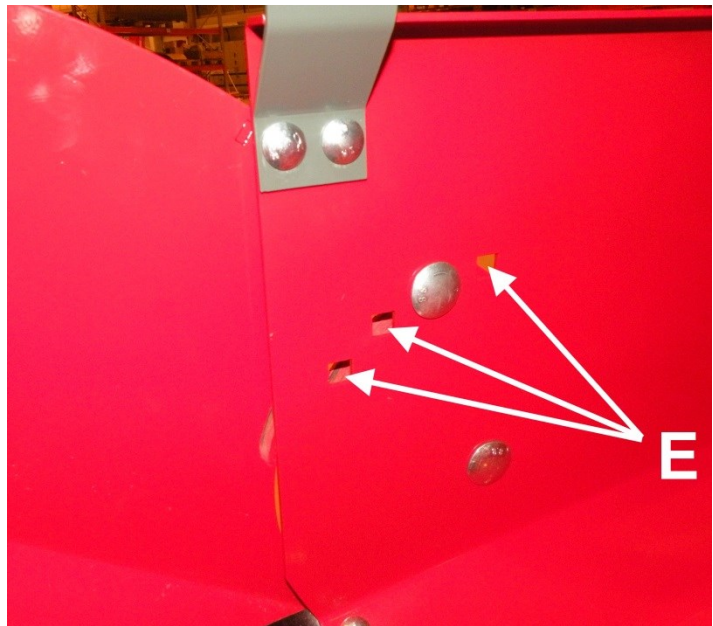

Figure 18.

When this side is vertical in relation to the ground, the conveyor is at its maximum angle.

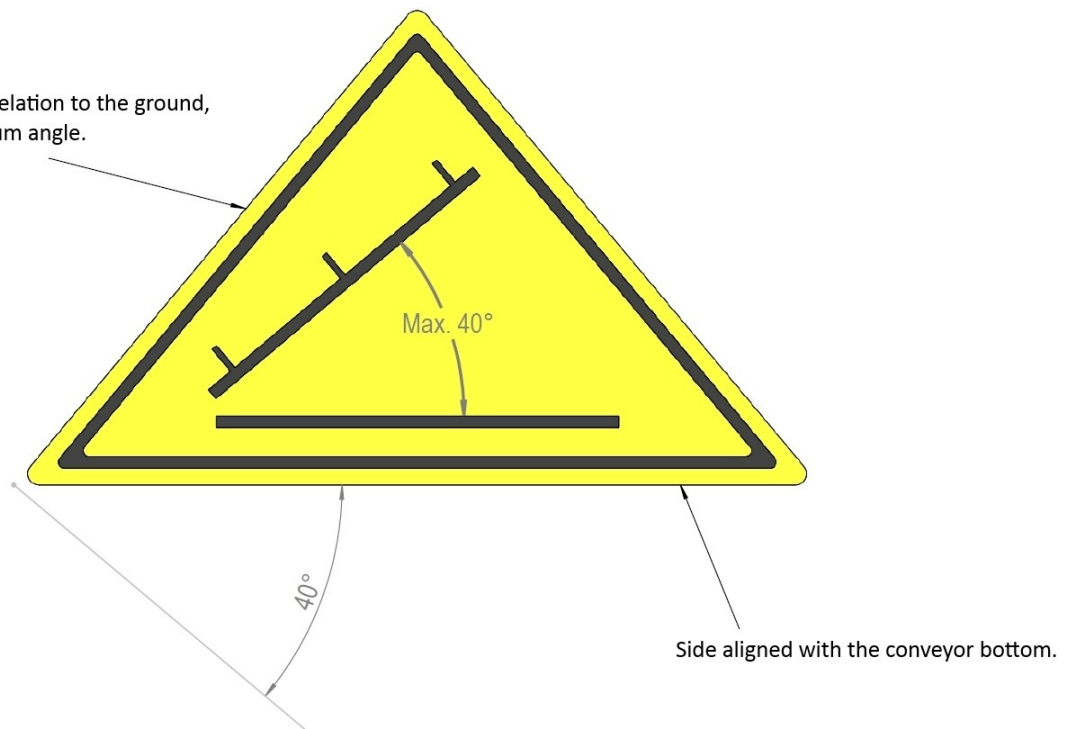

Figure 19

**Check the tension of the belt as follows:**

Lift the belt by the conveyor plate (centre of the conveyor), and ensure that the belt can be easily raised about 10 cm off the conveyor.

If the belt is too tight/loose, adjust the upper roller C up/down by loosening the locking nut A and turning the adjustment nut B in the desired direction, according to the situation (Figure 20). **Note! Also rotate the adjustment nut B (Figure 20) by the same amount from the other side of the conveyor.**

Finally, tighten the locking nut A firmly to prevent the vibration from turning the adjustment nut B (Figure 20).

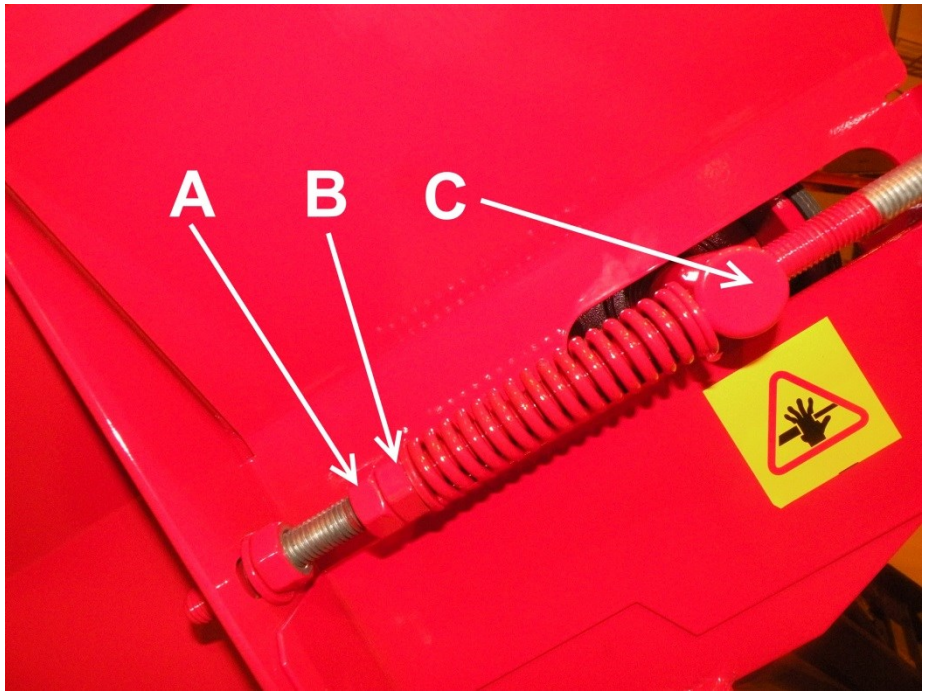

Figure 20.

If the belt runs too much to the right, for example, move the adjustment nut B in Figure 20 upwards, which will lift the right side of the roller and guide the belt further to the left. Move the nut down if the situation is the opposite.

### 3.6. Feeding and sawing wood

The input conveyor feeds the wood to be processed into the machine using rollers.

When feeding wood into the machine, make sure that it does not present a risk of your clothes, hands or other parts getting caught in the machine, for example, due to the shape of the log. Note! Adjust the limiting device to the desired measurement.

1. Choose the log to process. Note that the maximum log diameter is 25 cm. The knottiness and shape of the log increase the diameter.
2. Use your other hand to feed the log into the cutting section. Do not insert your hand into the machine!
3. Once the log stops for cutting in the mechanical limiting device, lock the log in place (during the final cut, for example) with the wood gripper by lifting the handle C (Figure 9).
4. Cut the log by pulling the lever A (Figure 12) down, which activates the saw chain, and guide the saw bar into the lower position by continuing to pull the lever A (Figure 12) down.
5. Return the saw bar to the raised position by lifting the lever A up, which automatically starts the splitting function.

### Placing logs on the input table

We recommend that you use an auxiliary device, such as the HakkiFeed 371 log rack. If a log rack is not attached to the splitter, the maximum permitted log length is 4.0 m. Always lift and place wood on the input table in a safe manner that does not endanger the operator.

**Note! Do not place a log directly onto the input table with a loader!**

**Note! Always place logs on the input table with the butt end first! (This ensures that the log's centre of gravity stays on the conveyor.)**

### Sawing the last log

When sawing wood, the second to last piece should be sawn in such a way that the remaining piece is of a sufficient length. The last log is a sufficient length when it stays firmly under the wood gripper and the sawing is steady and safe. The last log can easily be correctly dimensioned based on the label in Figure 21.



Figure 21.

### 3.7. After use

1. Once you have stopped processing firewood, turn off the machine and disconnect it from the power source. Remove the firewood from the splitting groove and the conveyor.
2. Close the adjustment screw for the saw chain lubrication (Figure 33).
3. Ensure that the machine has not been damaged.
4. Clean the machine.

If you will not be using the firewood processor for a while, do the following:

5. Use a forklift to hoist the firewood processor and carefully move it to a location where you can place the input and output conveyors into their transport and storage positions.
6. Place the conveyors into the transport and storage position.
7. Clean and maintain the machine.
8. Store the machine according to the instructions in Section 10.

## 4. Maintenance and adjustment of the machine

Before any maintenance, adjustment, replacement or cleaning procedures, the machines must always be de-energised by disconnecting the power source (see Section 4.1). Only use spare parts that are supplied by the manufacturer or your retailer. If the guards of the machine have to be removed for maintenance, they must always be reattached before activating the machine. After maintenance and adjustment measures, the machine must always be test run according to the instructions in Section 3.3.

### 4.1. Disconnecting the machine from its power source

#### Combustion engine model

Turn off the machine as instructed in Section 3.4.

#### Tractor-powered model

Do as instructed in Section 3.4.

#### Electrically-powered model

Follow the instructions in Section 3.4 and disconnect the machine's power cable from the socket.

#### Hydraulically powered model

Turn off the tractor and disconnect the machine's hydraulic hoses from the tractor.

**Note! Once you have disconnected the machine from its power source, always ensure that the machine is completely inactive before performing any other measures!**

### 4.2. Adjusting the log length

The Hakki Pilke Hawk 25 is equipped with a mechanical log limiting device with a stepless adjustment value of 15–40 cm.

1. Turn the machine off and open the machine's guard (Figure 13).
2. Loosen the tightening screw A of the limiter plate, move and tighten the lower edge of the limiter plate to the desired position (Figure 22).
3. If necessary, adjust the height/angle of the limiter plate using the adjustment bolt B and nut C (Figure 22).

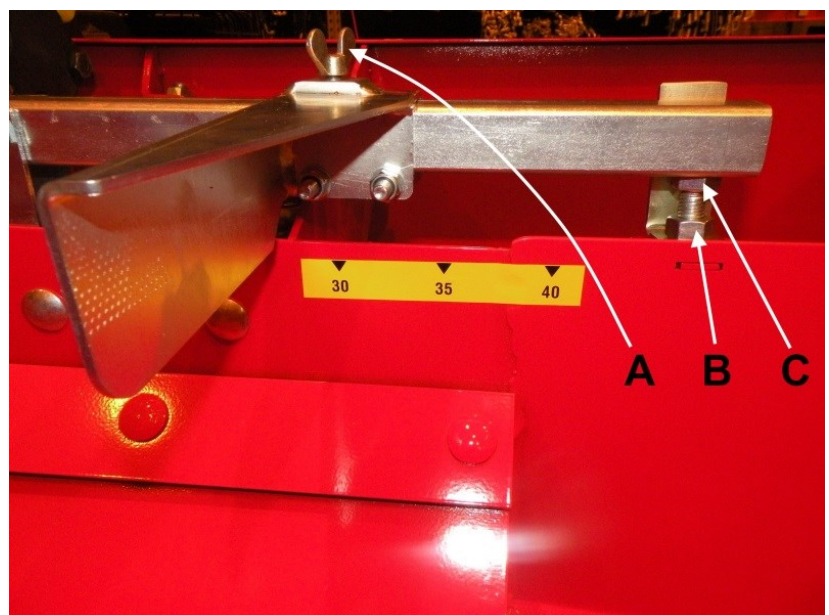

Figure 22. Log length adjustment.

### 4.3. Adjusting and detaching the splitting knife

By using the control lever D in Figure 12, the splitting knife can be moved mechanically up (lever to the left) or down (lever to the right), in accordance with Figure 23. Logs should always be as central as possible when passing the knife in order to keep the size of the firewood consistent.

The knife can be driven to the lowest position by raising the knife and clearing the space under the knife. Deactivate the machine and disconnect it from the power source for the duration of cleaning (tractor-powered and electrical models).

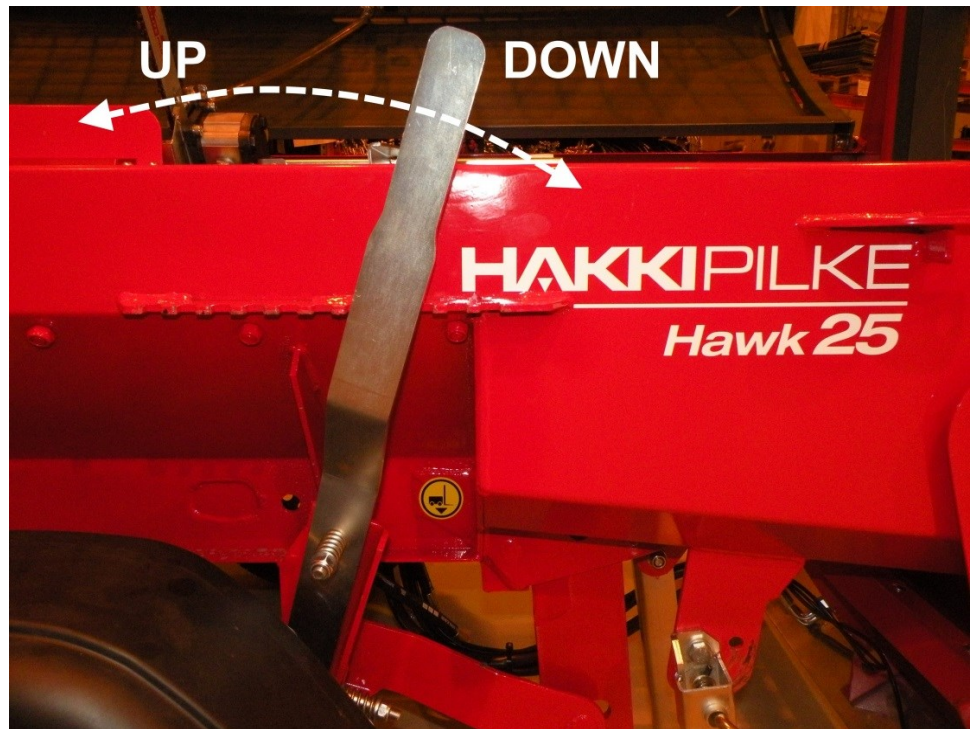

Figure 23.

#### Detaching the splitting knife:

1. Turn off the machine and disconnect it from the power source.
2. Test the machine to make sure it does not function.
3. Open the machine guard.
4. Clear the space below the splitting knife of wood and lower the knife to the lowest possible position, which releases the height adjustment shaft A from the splitting knife groove B (Figure 24).
5. Remove the splitting knife. **Note! Use protective gloves and exercise special care when handling the knife.**

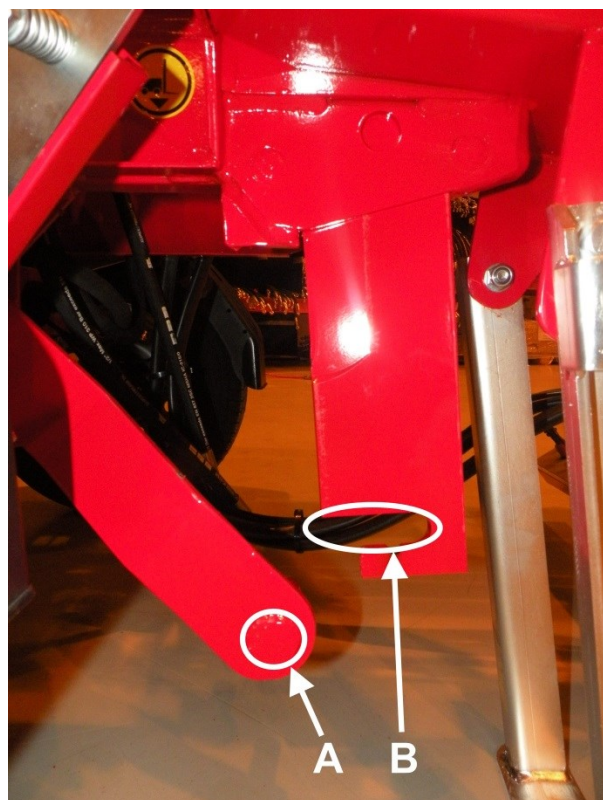

Figure 24.

#### 4.4. Adjusting the length of the splitting motion

The stroke length of the splitting cylinder can be adjusted as follows:

1. Turn off the machine and disconnect it from the power source (tractor-powered and electrical models).
2. Remove the fastening bolts in Figure 25 (5 pcs) and the input table cover.
3. The adjustment screw B (Figure 26) defines the stroke length of the splitting cylinder, i.e. the phase in which the splitting valve turns from the splitting position to the reverse position. If the stroke is too short, for example, (i.e. the splitting cylinder does not go sufficiently close to the splitting knife) rotate the adjustment screw B further in relation to the plate A (Figure 26).
4. The adjustment screw C (Figure 26) defines the initial position of the splitting cylinder. By adjusting the screw, you can affect when the splitting valve stops the reverse motion of the splitting cylinder and stops the cylinder altogether. If the splitting beam will not go into the initial position properly (i.e. the beam remains visible on the side of the splitting groove), turn the adjustment screw C further in relation to the plate D.
5. Fasten the input table cover back in place after maintenance.

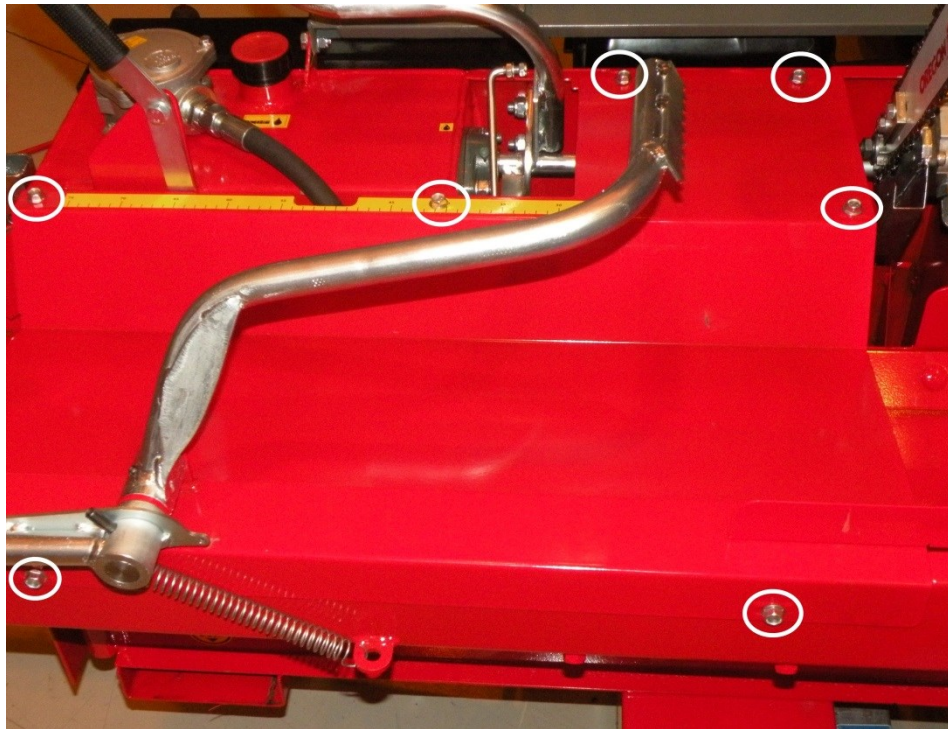

Figure 25.

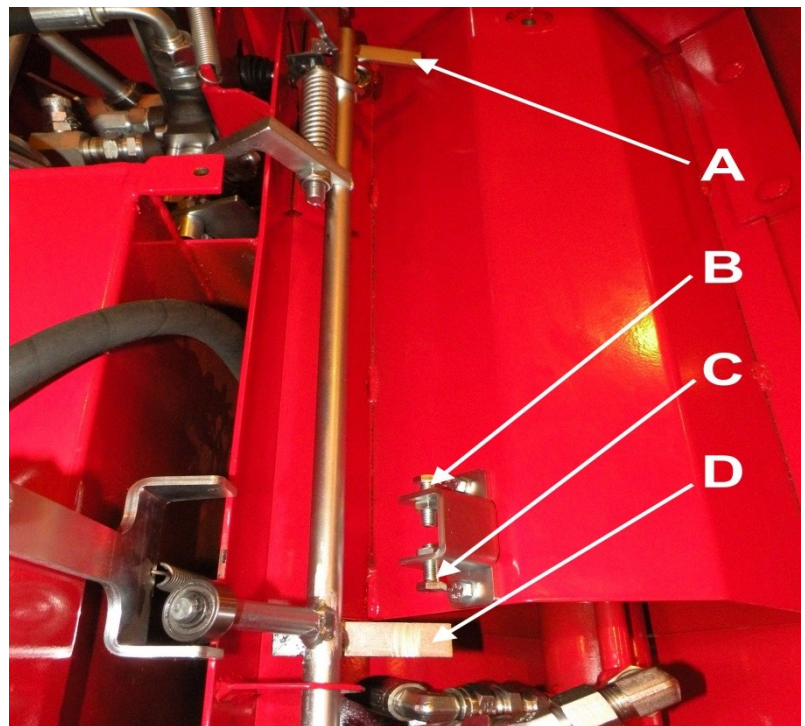

Figure 26.

## 4.5. Cutting blade and drive end

If the cutting blade of the machine does not penetrate the wood properly or the cut is skewed, the saw chain is most likely blunt. It is a good idea to keep a replacement chain handy, so that you do not need to interrupt your work to sharpen the chain.

### Replacing and tightening the saw chain

Replace the saw chain as follows:

1. Shut down the machine and disconnect it from its power sources.
2. Test the machine to make sure it does not function.
3. Open the guard.
4. Loosen the saw bar bolts B (Figure 27).
5. Loosen the adjustment screw D for saw chain tension as far as it goes (Figure 27).
6. Remove the old saw chain.
7. Install the new saw chain and ensure that the cutting teeth come first in relation to the rotating direction.
8. Lift the saw bar from the front section to tighten the chain as you are attaching the bolts.
9. Tighten the saw chain with the adjustment screw D (Figure 27).

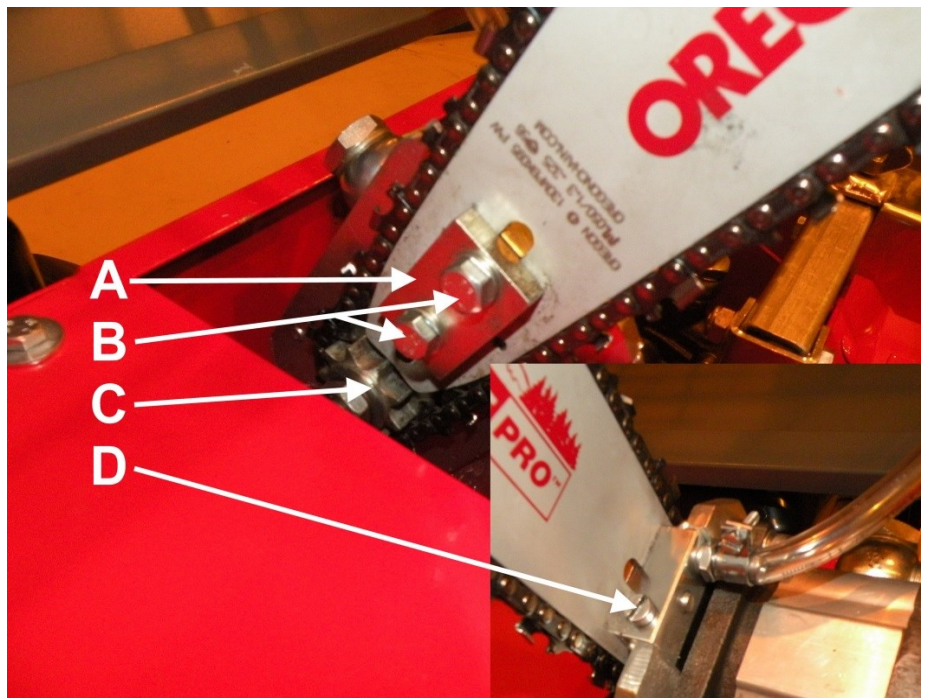

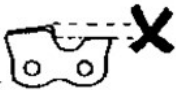

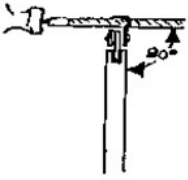

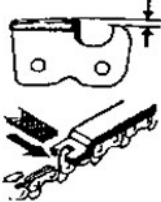

Figure 27.

To check the tension of the saw chain, wear protective gloves and pull the lower edge of the chain. The tension is correct if you can pull out **three teeth** by applying moderate force.

**Note! Use protective gloves when handling the blade!**

## Instructions for sharpening the saw chain

		
<p>Excessive filing with a file that is too narrow.</p>	<p>The lowering dimension of the saw chain is too great; should be 0.65mm.</p>	<p>The lowering dimension is too small.</p>
		
<p>When filing a chain tooth, hold the file at a 90-degree angle in relation to the bar and chain, and always begin the filing stroke from the inside of the chain.</p>	<p>Remember right filing direction.</p>	<p>The correct lowering dimension is 0.65mm.</p>

**Note! The diameter of the file must be 4.8 mm.**

## Replacing the blade flange

Replace the saw bar as follows:

1. Remove the saw chain according to steps 1–6 of Section 4.5 “Replacing and tightening the saw chain”.
2. Remove the saw bar bolts B, and detach the fastening plate A (Figure 27).
3. Remove the saw bar from the groove.
4. Place the new saw bar against the gear wheel C, twist it into the groove and loosely attach the saw bar bolts B and fastening plate A (Figure 27).
5. Attach and tighten the saw chain according to steps 7–9 of Section 4.5 “Replacing and tightening the saw chain”.

## 4.6. Changing the oil

Change the hydraulic oil of the firewood processor as follows:

1. Turn off the machine and disconnect it from the power source.
2. Open the filler cap A of the hydraulic oil tank (this will allow the oil to drain more easily, Figure 28).
3. Open the drain plug C (Figure 29) and drain the oil into a suitable container.
4. Open the cover of the hydraulic filter B (Figure 28) and replace the filter.
5. Tighten the plug C (Figure 29) firmly, and fill the tank with fresh oil (approx. 33 litres) in such a way that the oil surface settles about 7 cm below the filler cap.
6. Dispose of the waste oil in the appropriate manner.



Figure 28.

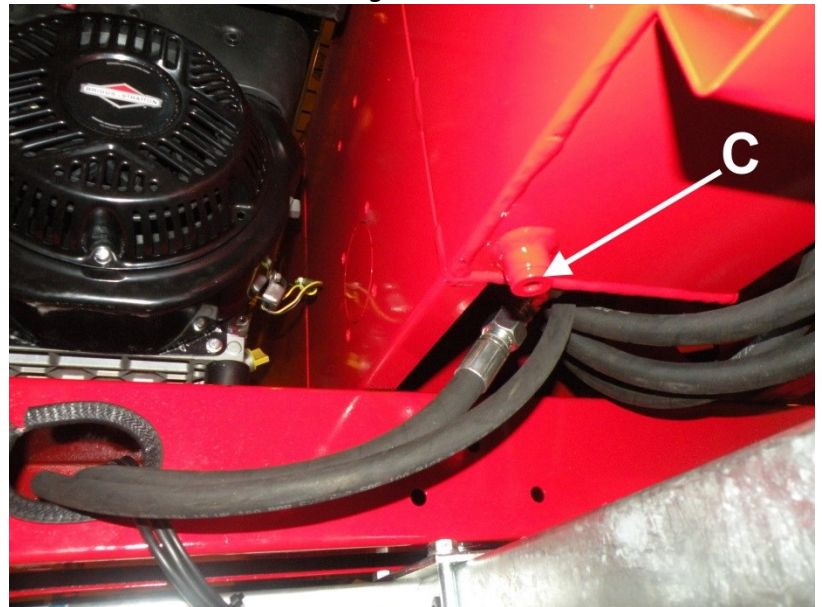

Figure 29.

## 4.7. Conveyor maintenance

### Replacing and tightening the belt of the output conveyor

The instructions for tightening and alignment of the output conveyor are presented in Section 3.5.

Replace the belt of the output conveyor as follows:

1. Turn off the machine and disconnect it from the power source.
2. Move the belt joint to the beginning of the conveyor.
3. Loosen the belt by lowering the upper roller C of the conveyor (figure 14).
4. Disconnect the joint by opening the bolts.
5. Remove the old belt.
6. Install the new belt in place in such a way that the joint is at the front of the conveyor, and attach the connecting pieces.
7. Tighten the belt to a suitable tension, and adjust the belt so that it runs straight on the conveyor.

**The belt is at the correct tension when its middle section is raised approx. 10 cm when the conveyor is in the operating position. An excessively tight belt may be damaged more easily, and it places unnecessary strain on the bearings of the conveyor.**

### Replacing the plates of the output conveyor

The plates of the output conveyor can be replaced by disconnecting the bolt joints (3 x M8) fastening the plates and replacing the plates with new ones. When replacing a plate, it is advisable to rotate the belt so that the damaged plate is above the conveyor. Shut the machine down and disconnect it from the power source for the duration of the procedure.

## 4.8. Lubrication

All of the log splitter's lubrication points, which require Vaseline, have been labelled. The lubrication must be performed every 10 hours. There are nine lubrication points, presented in figures 30 and 31 below.

1. The right-side nipple A of the saw shaft (Figure 30).
2. The left-side nipple B of the saw shaft (Figure 31).

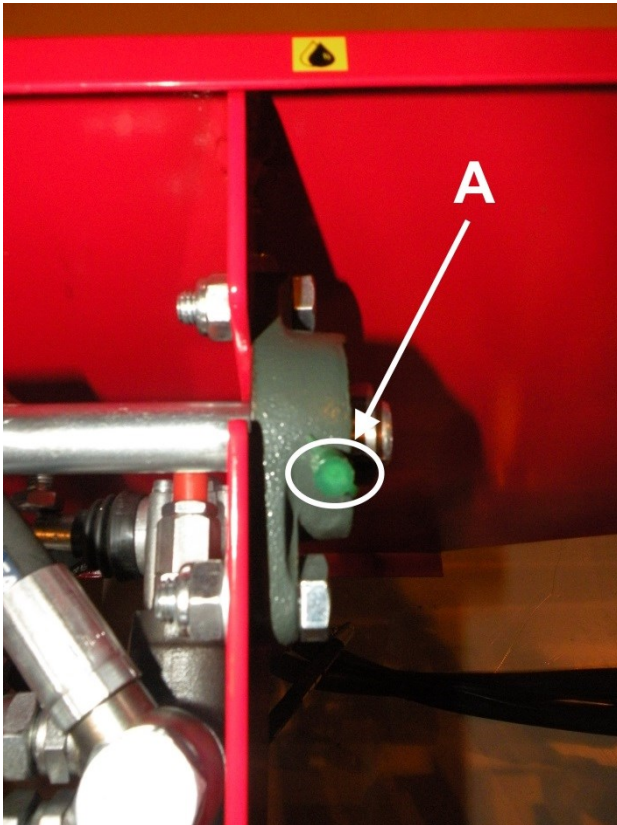

Figure 30.

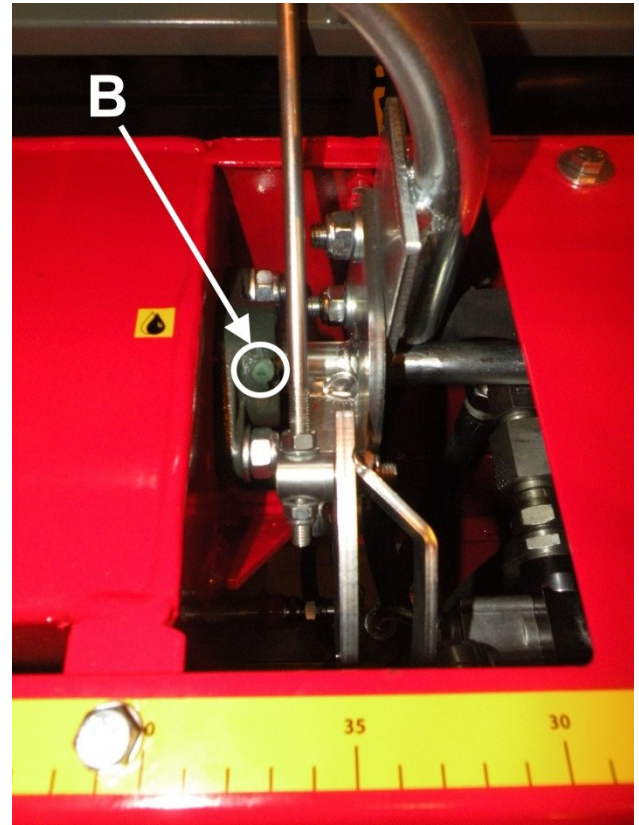

Figure 31.

## Saw chain lubrication

In the Hakki Pilke Hawk 25 machine, the saw chain oil is supplied to the saw bar by an oil pump (Figure 33). The pump receives its hydraulic pressure from the saw motor, meaning that whenever the saw motor is activated, the pump performs a stroke and pumps chain oil to the saw bar. When the saw motor stops spinning while waiting for a new cutting action, the pressure spring inside the pump pushes the pump piston back to its initial position. Therefore, **it is not advisable to run the saw motor for longer than necessary for cutting wood** so that the pump piston can return to the initial position. If necessary, the pump's stroke length can be adjusted by adding (less oil supplied) or removing (more oil supplied) the stroke length washers inside the pump.

Add saw chain oil through the filler cap A. Oil must be added, at the latest, when the colour of the chain oil hose B (Figure 33) begins to clear up (i.e. the hose contains to oil).

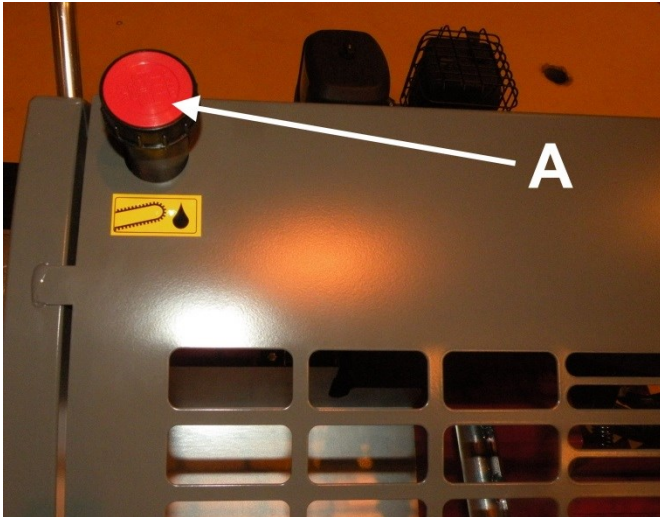

Figure 32.

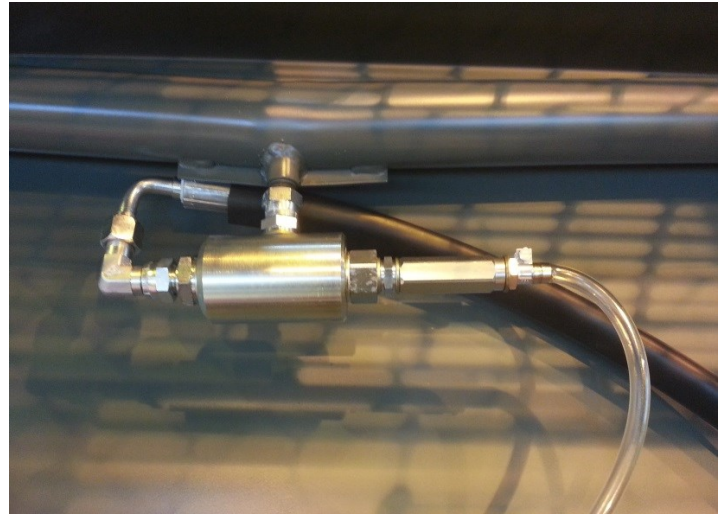

Figure 33.

#### 4.9. Pressure adjustment valves

The Hakki Pilke Hawk 25 is equipped with two relief valves (A and B in figures 34 and 35). The cartridges have been adjusted to the correct settings at the factory. The machine's guarantee becomes void if the factory adjustments are changed. If you need to change the adjustments, first contact the manufacturer or retailer and follow their instructions carefully. Changing the cartridge settings incorrectly may damage the machine or render it hazardous to operate. The relief valve adjustments can be changed as follows: loosen the locking nut and rotate the hex socket screw clockwise or anti-clockwise (when turning the screw clockwise, the pressure increases and vice versa). Finally, tighten the locking screw.

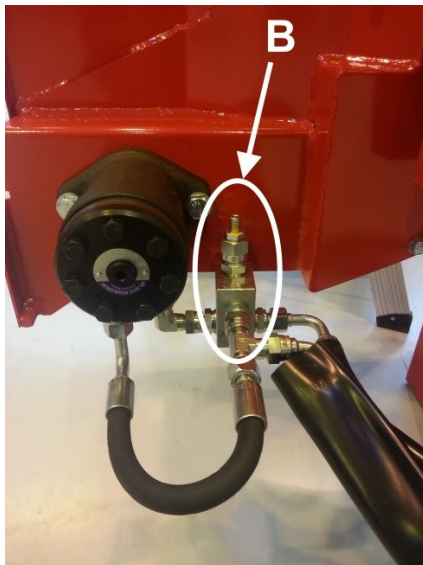

Figure 34.

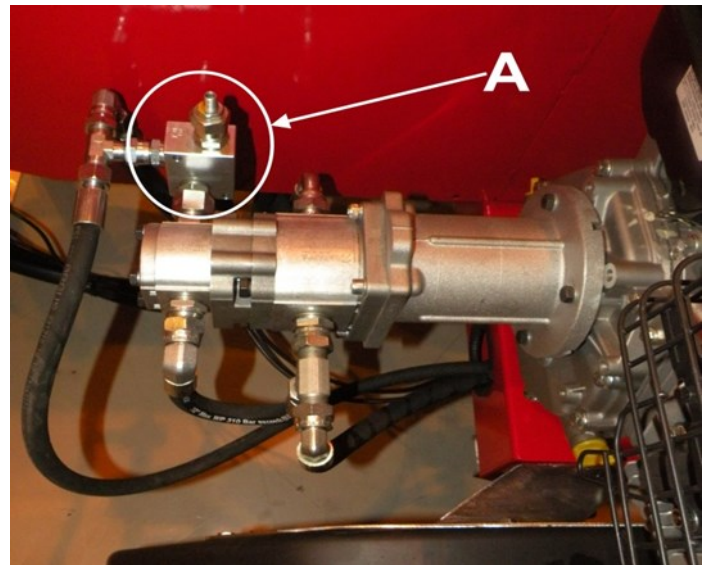

Figure 35.

## 4.10. Washing and cleaning

Loose debris and sawdust can be cleaned from the machine with pressurised air, for example. The machine can also be washed with a pressure washer, as long as the water jet is not aimed directly at the bearings or combustion engine.

Always ensure that the machine and the working area are sufficiently clean when operating the splitter. The machine must always be cleaned after use. Clean the machine as necessary, and always before storing the machine for a prolonged time. After washing, the splitter must be lubricated according to the instructions in Section 6.

## 4.11. Storage

Although the splitter is intended for outdoor use, it should be covered and stored in a sheltered location or indoors. Before prolonged storage, the machine must first be cleaned, then washed according to Section 9 and lubricated according to Section 6.

## 4.12. Maintenance table

Target	Task	Daily	Interval 100 h	Interval 500 h	Substance/accessory item
Hydraulic oil Normal conditions	Check 1st change Subsequent	X	X	X	Amount approx. 35 l For example, Teboil S 32
Oil filter	Always when changing oil		X	X	CR50
All levers	Lubrication		X		Lubrication oil
Cutting blade	Sharpen as necessary				13" 0.325" 56/1.5
Machine	Clean Wash	X			
Tyres (combustion engine/electrically- powered machine)	Air pressure check	X			Pressure 2.0 bar

## 5. Failures and remedial measures

### 5.1. Cause-effect table for failures and their removal

Failure	Cause	Remedial measure
The splitting force is insufficient to split the wood	The splitting valve's relief valve pressure is leaking (debris in the cartridge) or the pressure has been adjusted too low	1. Clean the splitting valve's adjustment cartridge of any debris and, if necessary, increase the pressure (180 bar = max) by tightening the adjustment screw

	2. The wood is too hard for the splitter	2. 3. See Section 5.3
The output conveyor does not move	1. The belt is too loose 2. The belt chafes heavily against the other side	1. Tighten the belt according to the instructions in Section 3.5 2. Adjust the alignment of the belt in accordance with Section 3.5
The saw chain does not properly sink into the wood	1. The saw chain is dull 2. The saw bar is crooked	1. Sharpen or replace the saw chain 2. File the bar to make it straight
The saw chain does not receive oil	The saw bar oil channel is blocked	Remove the bar (according to Section 4.5) and clean the channel

## 5.2. Jamming of the cutting blade and inefficient sawing

If the cutting blade gets jammed in the log, stop sawing and try again on another section of the log. If you need to remove the cutting blade from the wood manually, the machine must always be turned off and disconnected from its power source (electrical and tractor-powered models). If the cut is misaligned because the bar drags to one side, the degree of sharpness of the saw chain must be checked. A chain that is not evenly sharp will always drag towards the blunter side, which will make cutting a thick log impossible. Moreover, sawing with an evenly dull chain is inefficient, and the chain must be sharpened or replaced (see Section 4.5).

## 5.3. Jamming of the wood on the splitting knife

If a piece of wood gets jammed on the splitting knife in a situation where the splitting force is insufficient to push the piece past the knife despite several attempts to do so, do the following:

1. Restore the splitting cylinder into its initial position with the reversing lever B (Figure 12).
2. Ensure that the log to be split does not exceed the maximum allowable dimensions.
3. Lift the splitting knife to the highest possible position with lever D (Figure 12) and activate the splitting.
4. If necessary, cut a sufficiently thick piece of wood (approx. 10 cm), place it into the splitting groove behind the jammed piece and activate the splitting process. The new piece will then push the jammed piece past the knife.
5. Lower the knife some 5 cm lower and repeat step 3. Repeat step 4 until the jammed piece of wood has passed the knife piece by piece.

## 6. Hydraulics diagram

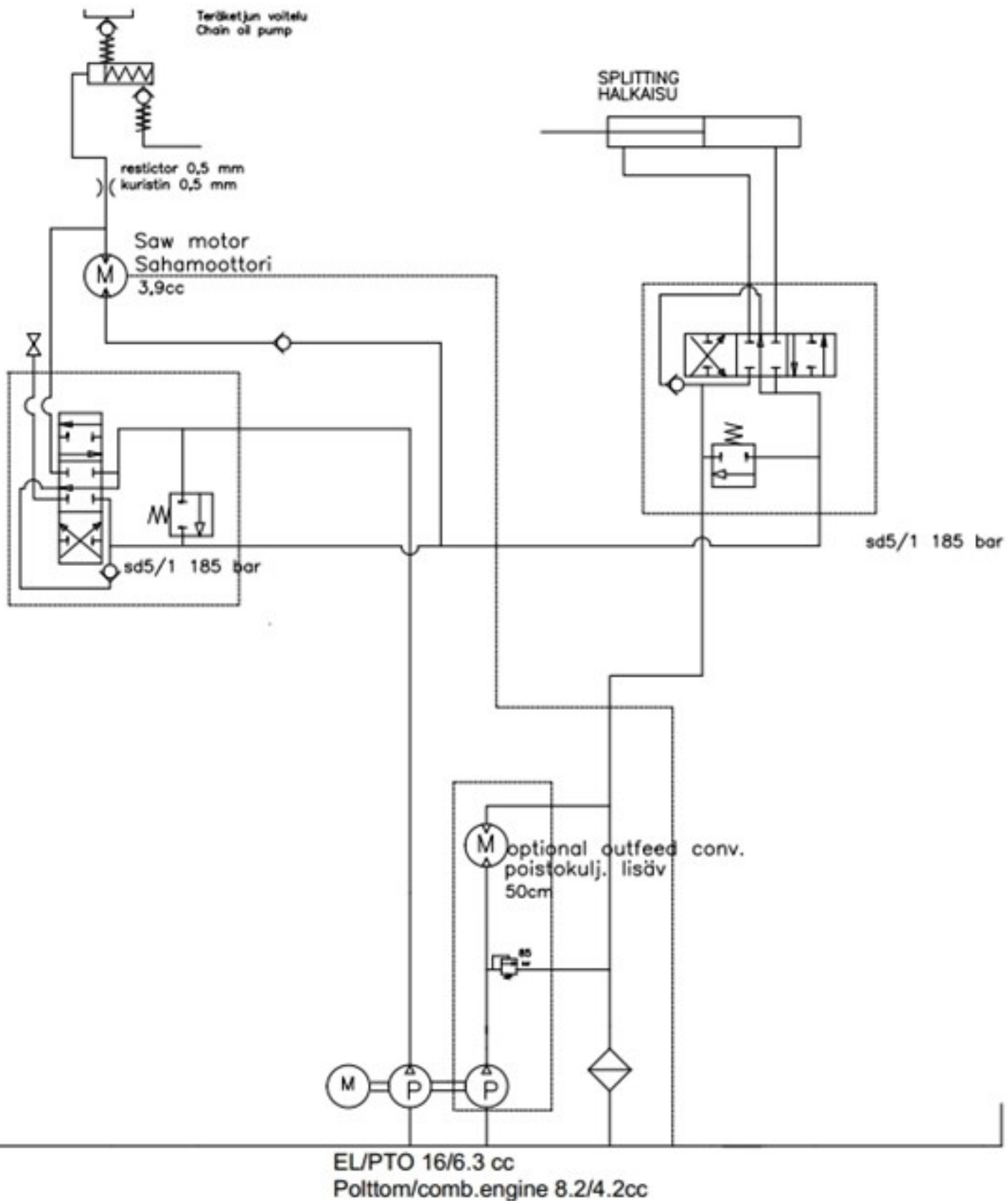

## 7. Guarantee terms

**“Guarantee terms come into force when you register your customership in the extranet service found on our website.”**

The guarantee is valid for the original buyer for 12 months, starting from the date of purchase, but for no more than 1 000 operating hours.

In guarantee matters, always contact the machine’s seller before undertaking any procedures.

A guarantee demand must be issued to the seller **immediately** upon discovery of a defect. If the defect concerns a damaged part or component, please send a photograph of the damaged part or component to the seller, if possible, so the fault can be identified. When submitting a guarantee claim, the buyer must always include the type and serial number of the machine and present a receipt that includes the date of purchase. Guarantee claims must be submitted to an authorised retailer.

### **The guarantee covers the following.**

- Parts damaged in normal use due to faults in material or manufacture.
- Reasonable expenses caused by repairing a fault in accordance with the agreement between the seller or buyer and manufacturer. Faulty parts will be replaced with new ones. A faulty part or parts replaced due to a material fault should be returned to the manufacturer through the retailer.

### **The guarantee does not cover:**

- damages caused by normal wear and tear (for example blades, mats and belts), improper use or use contrary to the instruction manual;
- damages caused by negligence of maintenance or storage procedures detailed in the instruction manual;
- damages caused during transport;
- cutting blades, V-belts and oil, and normal adjustment, care, maintenance or cleaning procedures;
- defects in a machine to which the buyer has carried out or commissioned structural or functional changes, to the degree that the machine can no longer be considered equivalent to the original machine;
- other potential costs or financial obligations resulting from the procedures mentioned above;
- indirect costs;
- travel costs resulting from guarantee repairs;
- The guarantee for parts replaced during the guarantee period of the machine expires at the same time as the machine’s guarantee;
- The guarantee is void if the ownership of the machine is transferred to a third party during the guarantee period;
- The guarantee is void if any of the machine’s seals have been broken.

If a fault or defect reported by the customer is found to not be covered by the guarantee, the manufacturer has the right to charge the customer for the pinpointing and possible repair of the fault or defect in accordance with the manufacturer's current price list.

This guarantee certificate indicates our responsibilities and obligations in full and it excludes all other responsibilities.

